



PROFTECH

SPÓŁKA Z O.O.



AB 994

Research laboratory
accredited by PCA,
Nr AB 994

Scopes of accreditation:

- concentration and mass measurements of flow of fine particles
- measurements of concentration and mass flow of SO₂, NO_x, CO
- concentration measurements of CO₂, O₂
- concentration and mass flow measurements of OWO
- sampling for mass concentration determination of PCDD/PDF and dioxin type PCB
- sampling for concentration determination of (As; Cd; Cr; Co; Cu; Mn; Ni; Pb; Sb; Tl; V)
- sampling for concentration determination of Hg
- sampling and determination of concentration and mass flow of HCl
- sampling and determination of concentration and mass flow of HF
- sampling for determining the concentration of individual gaseous organic compounds
- calibration of Automated Monitoring systems,
- QAL2 procedure
- annual performance test of Automated Monitoring Systems, AST procedure
- noise measurement from machinery, installations and industrial plants

Chorzów, November 10th 2022
Our ref. No.: PW/22/11/22

Report No PW/22/11/22

on concentration measurements of dioxins, furans, heavy metals (As; Cd; Cr; Co; Cu; Mn; Ni; Pb; Sb; Tl; V and Hg) emitted into environment from stationary emission source No. 001 (waste incineration boiler stack), located at UAB Vilniaus Kogeneracinė Jėgainė, Jočionių g. 13, 02300 Vilnius

Client name and address:

UAB Vilniaus Kogeneracinė Jėgainė
Žvejų St. 14,
LT-09310 Vilnius

Developed by:

mgr Grzegorz Bortel

Calculation and data transfer checked by:

inż. Dariusz Guja

Verified by:

Company manager - inż. Dariusz Guja

Copy number: 1/2

DYREKTOR
inż. Dariusz Guja

ul. Kurta Aldera 44
41-506 Chorzów
tel/fax: 0 32 247 37 24

www.proftech.com.pl
e-mail: proftech@proftech.com.pl

NIP: 627 252 46 31
KRS: 0000773369

bank account : PKO BANK POLSKI S.A. O/Katowice : IBAN PL62 1440 1172 0000 0000 0353 4332

Test Report No PW/22/11/22

List of contents:

- 1. PURPOSE AND SCOPE OF THE REPORT**
- 2. BASIS OF MEASUREMENTS EXECUTION**
- 3. MEASUREMENT TEAM**
- 4. MEASUREMENT RESULTS SUMMARY**
- 5. DESCRIPTION OF THE MEASUREMENT METHOD**
- 6. MEASUREMENT RESULTS**
- 7. MEASUREMENT DEVICES**
- 8. CERTIFICATE OF ACCREDITATION**
- 9. DIOXINS AND FURANS ANALYSIS RESULTS**
- 10. MEASUREMENT PLANE SCHEME**

Test Report No PW/22/11/22**4. MEASUREMENT RESULTS SUMMARY**

Below are presented measurement results summary, full measurement results are presented in chapter No 6, at page 9, 12 and 13.

Stationary emission source No. 001 (waste incineration boiler stack)	Concentration of the substance in the gas in the reference conditions O2 ref. 11%	PCDDF*	ng/m3 ref.	0,0038
	Emission limits	PCDDF	ng/m3 ref.	0,10
	Transgresssion	PCDDF	ng/m3 ref.	-
	Concentration of the substance in the gas in the reference conditions O2 ref. 11%	Cd*+Tl*	mg/m3 ref.	0,014
		Hg*	mg/m3 ref.	0,0042
		Sb*+As*+Cr*+Co*+Mn*+Cu*+Ni*+Pb*+V*	mg/m3 ref.	0,078
	Emission limits	Cd+Tl	mg/m3 ref.	0,05
		Hg	mg/m3 ref.	0,05
		Sb+As+Cr+Co+Mn+Cu+Ni+Pb+V	mg/m3 ref.	0,50
	Transgresssion	Cd+Tl	mg/m3 ref.	-
		Hg	mg/m3 ref.	-
		Sb+As+Cr+Co+Mn+Cu+Ni+Pb+V	mg/m3 ref.	-

*- the results obtained from the subcontractor (accredited)

Test Report No PW/22/11/22

5. DESCRIPTION OF THE MEASUREMENT METHOD**Measurement of the gas volumetric flow**

The flow rate and density of flue gases were determined according to Polish Standard PN-Z-04030-7:1994 „Testing of particulate content. The gravimetric method measurement of concentration and particulate mass flow in flue gases" Gravimetric dust monitor type MEGASYSTEM X-1 APIS and type "S" Pitot tube were used for the measurements. Measurement is accredited.

Accreditation range: differential pressure: > 10 Pa

Measurement O₂ content

The concentration of O₂ was determined using gas analyzers HORIBA PG-350E-HR and HORIBA PG-350E-EU equipped with testing probes 1750 mm long. The measurements were taken according to the procedure described in measurement unit as well as to EN Standard PN-EN 14789:2017 "Stationary source emissions - Determination of volume concentration of oxygen O₂ - Reference method - Paramagnetism". Measurement is accredited.

Accreditation range: O₂ content: 3-21%

Measurement CO₂ content

The concentration of CO₂ was determined using gas analyzers HORIBA PG-350E-HR and HORIBA PG-350E-EU equipped with testing probes 1750 mm long. The measurements were taken according to the procedure described in measurement unit as well as to ISO Standard PN-ISO 10396:2001 "Stationary Source Emissions - Sampling For The Automated Determination Of Gas Concentrations ". Measurement is accredited.

Accreditation range: CO₂ content: 0,1-20%

Measurement of heavy metals content

Sampling for the determination of concentrations and emissions of heavy metals (Cd, Tl, Sb , As, Cr, Co, Cu , Mn , Ni , Pb, V) was performed according to PN -EN 14385 : 2005. Analysis of metals (Cd , Tl , Sb , As, Cr, Co, Cu , Mn , Ni , Pb, V) was performed in the laboratory of OBiKŚ Sp. z o.o. in Katowice , accredited in this regard by the Polish Centre of Accreditation No. AB 213

Test Report No PW/22/11/22

Measurement of mercury (Hg) content

Sampling for the determination of concentrations and emissions of mercury (Hg) was made according to PN -EN 13211 + AC : 2006. Analysis of mercury (Hg) was made in a laboratory Eurofins OBIKŚ Sp. z o.o. in Katowice , accredited in this regard by the Polish Centre of Accreditation No. AB 213

PCDD+PCDF sampling and determination

PCDD/DF samples were taken according to the requirements of Polish Standard PN-EN 1948-1:2006 „ Stationary source emissions - Determination of mass concentration of PCDDs/PCDFs and dioxin-type PCBs - Part 1: Sampling of PCDDs/PCDFs”.

The three stages of PCDD/DF concentration and emission determination:

Stage I - sampling

For the determination of mass concentration of PCDD/DF proper sampling plays important role that affects following stages of the testing. The sampling were performed by means of the filtration and condensation method using PCDD/DF sampling conformed to European Standard PN-EN 1948-1:2006.

The following page shows the schematic diagram of the sampling system.

Stage II - laboratory analysis

The samples were analysed at the ALS Czech Republic, s.r.o accredited laboratory following the CSN EN 1948-2,3 methodology: The determination of polychlorinated dibenzo-p-dioxine, dibenzofurans in emission samples with the method of isotop dillution using HRGC/HRMS.

The dioxin and furans analyses were conducted at the ALS Czech Republic, s.r.o. Laboratory, specifically accredited for the test by the Český Institut Pro Akreditaci, o.p.s. , No L1163.

Stage III - development and the results and discussion

The last stage includes results collection from the previous stages, emission calculation and PCDD/DF concentration as well as comparison to the standards in force.

Test Report No PW/22/11/22

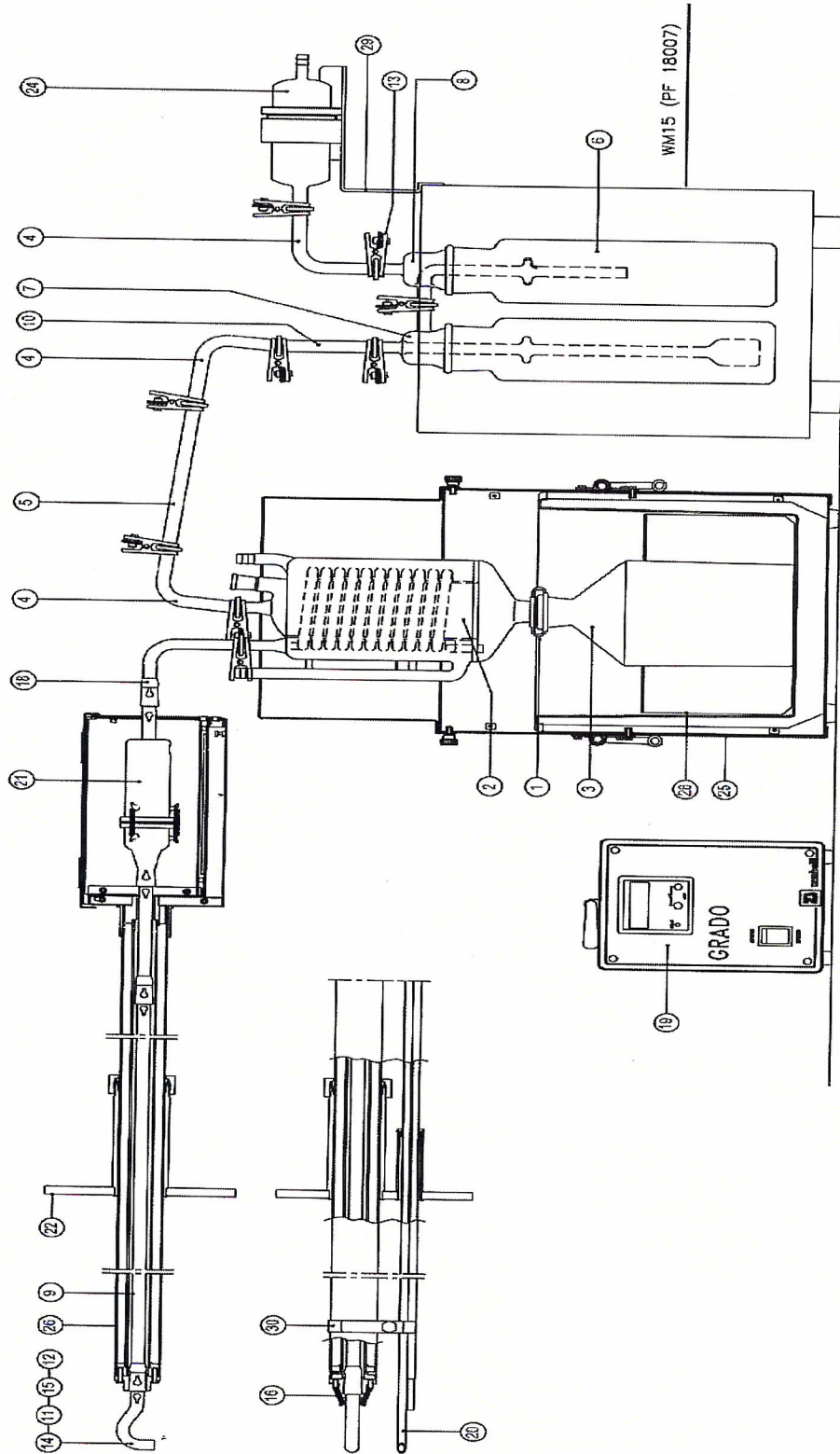

- Opis:
- 1. ferrule
 - 2. cooler
 - 5,10. aspiration path - tubes
 - 13. clamp
 - 20. Pitot tube „S” - type
 - 25. cooler casing
 - 3. condensation pot
 - 6-8. scrubbers
 - 16. holding springs
 - 21. filter casing
 - 26. heated probe
 - 4,18. aspiration path - elbows
 - 9. aspiration path - probe tube
 - 17. aspiration controller
 - 22. yoke
 - 28. cooler coil
 - 11,12,14,15. - aspiration endings
 - 19. temperature controller
 - 24. gas dryer
 - 29,30. support

Test Report No PW/22/11/22

6. MEASUREMENT RESULTS

Test Report No PW/22/11/22

- 1) Plant or unit name¹⁾: **Stationary emission source No. 001 (waste incineration boiler stack)**
- 2) Flue gases cleaning unit¹⁾: **Evaporative cooler, hydrated lime and active carbon reactor, bag filters unit (2x4)**
- 3) Emission source load during measurements¹⁾: **Boiler load ~66,5 MW,**
- 4) Fuel type or material mass flow in process¹⁾: **Waste ~21,2 t/h**
- 5) Location of sampling and measurements: **in duct, after flue gases cleaning unit**

Measurement reference number		14-10-01		X	X	
Date of measurement		14.10.2022				
Measurement time range		10:18-16:18				
Scope of test		Unit	Results	Uncertainty +/-	Method	
Meteorological conditions	Atmospheric pressure		hPa	1004,1	X	
	Ambient temperature		oC	12		
Measurement plane	Diameter		m	2,10		
	Area		m ²	3,4619		
The parameters of gas in line	Temperature		oC	37		
	Static pressure		Pa	-79		
	Differential pressure		Pa	92		
	Gas moistness grade X		kg/kg	0,041		
	Average velocity		m/s	10,8		0,1
	Chemical composition	O ₂	%	7,4		0,2
		CO ₂	%	11,4	0,4	
	Wet gas density during testing		kg/m ³	1,142	X	
	Gas density in normal conditions		kg/m ³ N	1,310		
	Gas density in conventional conditions		kg/m ³ U	1,345		
Concentration of the substance in the gas in reference conditions O ₂ ref. 11%	PCDDF*	ng/m ³ ref.	0,0038	0,0011	PN-EN 1948:2006	
Gas volume flow	measurement conditions		m ³ /h	134100	3623	
	normal conditions		m ³ N/h	116961	3209	
	standard conditions		m ³ U/h	109387	5216	
	reference conditions O ₂ ref. 11%		m ³ ref./h	148766	7660	
Emission limits	PCDDF*	ng/m ³ U	0,10	X	X	
Transgerssion	PCDDF*	ng/m ³ U	-			

*- the results obtained from the subcontractor (accredited)

¹⁾-information obtained from the client

Test Report No PW/22/11/22Notes:

Normal conditions designate the temperature of 273 K and pressure of 101,3kPa, defining normal cubic meter m³N. The standard conditions designate the temperature of 273K, pressure of 101,3 kPa and dry gases (steam contents less than 5 g/kg of flue gas), defining standard cubic meter, m³U

The specified expanded uncertainty comes from standard uncertainty multiplied by expansion coefficient k = 2, which provides 95% level of confidence for normal distribution. Uncertainty takes into account the sampling and analysis.

Registry of samples delivered to the laboratory: P/63/10/22, P/64/10/22

Date of delivery to the laboratory: 15.10.2022

Date of analysis: 17.10.2022 - 31.10.2022

Field blanks:

ID/ number of sample	Type of substance	The criterion of the blank [ng/m ³] 11%O ₂	The value of the blank [ng/m ³] 11% O ₂	Result [+/-]
P/64/10/22	PCDD/DF	0,01	0,0018	+

PCDD/DF (PN-EN 1948:2006):

sampling method: condensation - adsorption method

filter parameters: 19 x 90 mm, filter efficiency: 99,998 %

sampling plane: 2 measurement axis

oxygen reference : 11 %

time of dioxins and furans measurement: 10:18 – 16:18 (360 min)

nozzle diameter: 6 mm

probe temperature: 120 °C

scrubbers temperature 5 °C

aspired gas volume 5,59 m³

average sampling flow 15,5 l/min

isokinetic ratio: 96,4 %

leak test: + / +

gas meter temperature 17 °C

gas meter pressure 0 bar

spiking pattern: filter surface

absorption solution: 100 ml H₂O dest. + 50 ml 2-etoksyetanol

recovery: 84 % ¹³C₁₂-2,3,4,7,8-PECDF, />50%/

60 % ¹³C₁₂-1,2,3,6,7,8-HxCDF, />50%/

60 % ¹³C₁₂-1,2,3,4,6,7,8 HpCDF. />50%/

TEQ sample mass: 0,026 ng

Test Report No PW/22/11/22

- 1) Plant or unit name¹⁾: **Stationary emission source No. 001 (waste incineration boiler stack)**
- 2) Flue gases cleaning unit¹⁾: **Evaporative cooler, hydrated lime and active carbon reactor, bag filters unit (2x4)**
- 3) Emission source load during measurements¹⁾: **Boiler load ~66,5 MW,**
- 4) Fuel type or material mass flow in process¹⁾: **Waste ~21,2 t/h**
- 5) Location of sampling and measurements: **in duct, after flue gases cleaning unit**

Measurement reference number			14-10-01		X	X	X
Date of measurement			14.10.2022				
Measurement time range			11:22 - 12:01	12:06 -12:45			
Scope of test		Unit	Results		Average	Uncertainty +/-	Method
Meteorological conditions	Atmospheric pressure	hPa	1003,6	1003,4	1003,5		PN-Z-04030-7:1994
	Air temperature	oC	11	11	11		
Measurement plane	Diameter	m	2,10				
	Area	m ²	3,4619				
Stack gas parameters	Temperature	oC	34,7	34,6	34,7		
	Static pressure	Pa	-59,5	-68,9	-64,2		
	Dynamic pressure	Pa	75,0	86,7	80,9		
	Gas moistness grade X	kg/kg	0,042	0,042	0,042		
	Average velocity	m/s	9,3	10,0	9,6	0,3	
	Chemical composition	O ₂	%	7,70	7,70	7,70	
		CO ₂	%	11,10	11,10	11,10	0,43
	Wet gas density during testing	kg/m ³	1,149	1,149	1,149		
	Gas density in normal conditions	kg/m ³ N	1,308	1,308	1,308		
	Gas density in standard conditions	kg/m ³ U	1,343	1,343	1,343		
Concentration of the substance in the gas in reference conditions O ₂ ref. 11%	As gaseus*	mg/m ³ _{ref}	< 0,008876	< 0,008983	< 0,008930	0,002275	
	As dust*	mg/m ³ _{ref}	< 0,001012	< 0,000965	< 0,000989	0,000253	
	As*	mg/m ³ _{ref}	< 0,009888	< 0,009948	< 0,009918	0,002289	
	Sb gaseus*	mg/m ³ _{ref}	< 0,017752	< 0,017967	< 0,017860	0,004549	
	Sb dust*	mg/m ³ _{ref}	< 0,002025	< 0,001931	< 0,001978	0,000506	
	Sb*	mg/m ³ _{ref}	< 0,019777	< 0,019898	< 0,019838	0,004577	
	Cd gaseus*	mg/m ³ _{ref}	< 0,003550	< 0,003593	< 0,003572	0,000917	
	Cd dust*	mg/m ³ _{ref}	< 0,000405	< 0,000386	< 0,000396	0,000102	
	Cd*	mg/m ³ _{ref}	< 0,003955	< 0,003979	< 0,003967	0,000923	
	Co gaseus*	mg/m ³ _{ref}	< 0,000710	< 0,000719	< 0,000715	0,000183	
	Co dust*	mg/m ³ _{ref}	< 0,000081	< 0,000077	< 0,000079	0,000020	
	Co*	mg/m ³ _{ref}	< 0,000791	< 0,000796	< 0,000794	0,000184	
	Mn gaseus*	mg/m ³ _{ref}	0,004573	0,012720	0,008647	0,002246	
	Mn dust*	mg/m ³ _{ref}	< 0,000202	< 0,000193	< 0,000198	0,000051	
	Mn*	mg/m ³ _{ref}	0,004775	0,012913	0,008844	0,002247	
	Cu gaseus*	mg/m ³ _{ref}	0,023432	0,016960	0,020196	0,005169	
	Cu dust*	mg/m ³ _{ref}	< 0,000162	< 0,000154	< 0,000158	0,000058	
	Cu*	mg/m ³ _{ref}	0,023594	0,017114	0,020354	0,005169	
	Ni gaseus*	mg/m ³ _{ref}	< 0,001420	< 0,001437	< 0,001429	0,000367	
	Ni dust*	mg/m ³ _{ref}	0,001523	< 0,000154	0,000839	0,000216	
	Ni*	mg/m ³ _{ref}	0,002943	< 0,001591	0,002267	0,000426	
	Pb gaseus*	mg/m ³ _{ref}	< 0,004473	< 0,004528	< 0,004501	0,001159	
	Pb dust*	mg/m ³ _{ref}	< 0,000510	< 0,000487	< 0,000499	0,000129	
	Pb*	mg/m ³ _{ref}	< 0,004983	< 0,005015	< 0,004999	0,001166	

Test Report No PW/22/11/22

	V gaseus*	mg/m ³ _{ref}	< 0,000888	< 0,000898	< 0,000893	0,000227	PN-EN 14385:2005
	V dust*	mg/m ³ _{ref}	< 0,000101	< 0,000097	< 0,000099	0,000025	PN-EN 14385:2005
	V*	mg/m ³ _{ref}	< 0,000989	< 0,000995	< 0,000992	0,000228	PN-EN 14385:2005
	Cr gaseus*	mg/m ³ _{ref}	0,008734	0,008480	0,008607	0,002236	PN-EN 14385:2005
	Cr dust*	mg/m ³ _{ref}	0,003199	< 0,000232	0,001716	0,000443	PN-EN 14385:2005
	Cr*	mg/m ³ _{ref}	0,011933	0,008712	0,010323	0,002279	PN-EN 14385:2005
	TI gaseus*	mg/m ³ _{ref}	< 0,008876	< 0,008983	< 0,008930	0,002275	PN-EN 14385:2005
	TI dust*	mg/m ³ _{ref}	< 0,001012	< 0,000965	< 0,000989	0,000253	PN-EN 14385:2005
	TI*	mg/m ³ _{ref}	< 0,009888	< 0,009948	< 0,009918	0,002289	PN-EN 14385:2005
Gas volume flow	measurement conditions	m ³ /h	115281	124005	119643	3233	PN-Z-04030-7:1994
	normal conditions	m ³ _n /h	101270	108934	105102	2884	
	standard conditions	m ³ _u /h	94689	101855	98272	4686	
	reference conditions O2 ref. 11%	m ³ _{ref} /h	125936	135467	130702	6730	
Emission limits	Cd*+TI*	mg/m ³ _{ref}	0,05				
	Sb*+As*+Cr*+Co*+Mn*+Cu*+Ni*+Pb*+V*	mg/m ³ _{ref}	0,50				
Concentration of the substance in the gas in reference conditions O2 ref. 11%	Cd*+TI*	mg/m ³ _{ref}	0,014				
	Sb*+As*+Cr*+Co*+Mn*+Cu*+Ni*+Pb*+V*	mg/m ³ _{ref}	0,078				

*- the results obtained from the subcontractor (accredited)

1)-information obtained from the client

Notes:

Normal conditions designate the temperature of 273 K and pressure of 101,3kPa, defining normal cubic meter m³N. The standard conditions designate the temperature of 273K, pressure of 101,3 kPa and dry gases (steam contents less than 5 g/kg of flue gas), defining standard cubic meter, m3U

The specified expanded uncertainty comes from standard uncertainty multiplied by expansion coefficient k = 2, which provides 95% level of confidence for normal distribution. Uncertainty takes into account the sampling and analysis.

Registry of samples delivered to the laboratory:P/65/10/22, P/66/10/22, P/67/10/22, P/68/10/22, P/69/10/22,
P/70/10/22, P/71/10/22,**Date of delivery to the laboratory:**

15.10.2022

Date of analysis:

17.10.2022 - 20.10.2022

Field blanks:

ID/ number of sample	Type of substance	The criterion of the blank [mg/m ³] 11%O ₂	The value of the blank [mg/m ³] 11% O ₂	Result [+/-]
P/69/10/22	Cd+TI	0,005	p.o.	+
P/69/10/22	Sb+As+Pb+Cr+Co+Cu+Mn+Ni+V	0,05	p.o.	+

p.o. – below the limit of quantification.

Test Report No PW/22/11/22

- 1) Plant or unit name¹⁾: **Stationary emission source No. 001 (waste incineration boiler stack)**
 2) Flue gases cleaning unit¹⁾: **Evaporative cooler, hydrated lime and active carbon reactor, bag filters unit (2x4)**
 3) Emission source load during measurements¹⁾: **Boiler load ~66,5 MW,**
 4) Fuel type or material mass flow in process¹⁾: **Waste ~21,2 t/h**
 5) Location of sampling and measurements: **in duct, after flue gases cleaning unit**

Measurement reference number		14-10-01		X	X	X		
Date of measurement		14.10.2022						
Measurement time range		12:49-13:28	13:32-14:11					
Scope of test		Unit	Results		Average	Uncertainty +/-	Method	
Meteorological conditions	Atmospheric pressure	hPa	1003,1	1002,9	1003,0		PN-Z-04030-7:1994	
	Air temperature	oC	11	11	11			
Measurement plane	Diameter	m	2,10					
	Area	m ²	3,4619					
Stack gas parameters	Temperature	oC	34,5	34,1	34,3			
	Static pressure	Pa	-58,1	-59,7	-58,9			
	Dynamic pressure	Pa	76,3	84,7	80,5			
	Gas moistness grade X	kg/kg	0,042	0,042	0,042			PN-EN 14790:2017
	Average velocity	m/s	9,3	9,8	9,6	0,3		PN-Z-04030-7:1994
	Chemical composition	O ₂	%	6,90	7,20	7,05		0,18
		CO ₂	%	11,70	11,50	11,60	0,44	PN-ISO 10396:2001
	Wet gas density during testing	kg/m ³	1,152	1,152	1,152		PN-Z-04030-7:1994	
	Gas density in normal conditions	kg/m ³ N	1,311	1,310	1,310		PN-Z-04030-7:1994	
Gas density in standard conditions	kg/m ³ U	1,346	1,345	1,346		PN-Z-04030-7:1994		
Concentration of the substance in the gas in reference conditions O ₂ ref. 11%	Hg gaseus*	mg/m ³ _{ref}	0,006371	< 0,001690	0,004031	0,005345	PN-EN 13211+AC:2006	
	Hg dust*	mg/m ³ _{ref}	< 0,000190	< 0,000191	< 0,000191	0,000066	PN-EN 13211+AC:2006	
	Hg*	mg/m ³ _{ref}	0,006561	< 0,001881	0,004221	0,005345	PN-EN 13211+AC:2006	
Gas volume flow	measurement conditions	m ³ /h	116154	122385	119269	3223	PN-Z-04030-7:1994	
	normal conditions	m ³ _n /h	102055	107652	104854	2878		
	standard conditions	m ³ _s /h	95426	100663	98044	4676		
	reference conditions O ₂ ref. 11%	m ³ _{ref} /h	134550	138914	136732	6995		
Emission limits	Hg*	mg/m ³ _{ref}	0,05					
Concentration of the substance in the gas in reference conditions O ₂ ref. 11%	Hg*	mg/m ³ _{ref}	0,004221					

*- the results obtained from the subcontractor (accredited)

¹⁾-information obtained from the client

Notes:

Normal conditions designate the temperature of 273 K and pressure of 101,3kPa, defining normal cubic meter m³N. The standard conditions designate the temperature of 273K, pressure of 101,3 kPa and dry gases (steam contents less than 5 g/kg of flue gas), defining standard cubic meter, m³U

The specified expanded uncertainty comes from standard uncertainty multiplied by expansion coefficient k = 2, which provides 95% level of confidence for normal distribution. Uncertainty takes into account the sampling and analysis.

Test Report No PW/22/11/22

Registry of samples delivered to the laboratory: P/72/10/22, P/73/10/22, P/74/10/22, P/75/07/22, P/76/07/22

Date of delivery to the laboratory: 15.10.2022

Date of analysis: 17.10.2022 - 19.10.2022

Field blanks:

ID/ number of sample	Type of substance	The criterion of the blank [mg/m ³] 11%O ₂	The value of the blank [mg/m ³] 11% O ₂	Result [+/-]
P/74/10/22	Hg	0,005	p.o.	+

p.o. – below the limit of quantification.

Work parameters of measurement system:**Heavy metals (PN-EN 14385:2005)**

Sampling plane: 2 measurement axis
 Sampling: isokinetic [x]
 nonisokinetic []
 Isokinetic ratio: 103,2 / 100,6 %
 Sampling time: 39,1 / 39,1 min
 Sampled volume: 0,082 / 0,081 m³
 Filter parameters: FT-50: Ø 0,50 mm, efficiency: 99,990 %, quartz (QMA)
 Impingers: impingers set No. 2 (absorption efficiency 98,1 %)
 Absorption solution: HNO₃/H₂O₂

Hg (PN-EN 13211 + AC:2006)

Sampling plane: 2 measurement axis
 Sampling: isokinetic [x]
 nonisokinetic []
 Isokinetic ratio: 103,1 % / 99,4 %
 Sampling time: 39,1 min / 39 min
 Sampled volume: 0,079 m³ / 0,081 m³
 Impingers: impingers set No. 1 (absorption efficiency 97,5 %)
 Absorption solution: No. I (manganese (VII) potassium / sulfuric acid (VI))

H₂O (PN-EN 14790:2017)

Sampling plane: 2 measurement axis
 Sampling equipment: titanium sampling line
 heated probe 2,0 m
 sampling pump: PT-01
 Cartridge No: H₂O content set No 1
 Sampling No: 1
 Sampling time: 39,1 min
 Sampling speed: ~2,0 l/min
 H₂O maas: 3,5 g
 absorption efficiency: 98,3 %

Test Report No PW/22/11/22**7. MEASUREMENT DEVICES**

Name of measuring device		X1- Apis
Type of measuring device		Isokinetic sampler S/N 0142
Certificate	Calibration No	G-355/22-208/22 29.08.2022 239/1/T/22 14.09.2022 818/302/LA/P/2022
Issued by		ZAP BESTWINKA LABOSERWIS SP. Z O.O. KATOWICE PLUM SP. Z O.O. KLEOSIN
Date of issue the certificate of calibration		29.08.2022 14.09.2022 22.09.2022
Expiration date of the certificate of calibration		-

Name of measuring device		HORIBA
Type of measuring device		PG-350E-EU
Certificate	Calibration No	130/1/AW/21
Issued by		Laboserwis Sp. z o.o. Katowice
Date of issue the certificate of calibration		28.05.2021
Expiration date of the certificate of calibration		-

Name of measuring device		Sampler
Type of measuring device		PT-01
Certificate	Calibration No	G-354/22-208/22 30.08.2022 1189/436/LA/T/2022 06.09.2022 786/281/LA/P/2022 09.09.2022
Issued by		ZAP BESTWINKA PLUM SP. Z O.O. KLEOSIN
Date of issue the certificate of calibration		30.08.2022 06.09.2022 09.09.2022
Expiration date of the certificate of calibration		-

Name of measuring device		Sampler
Type of measuring device		LIFETEK 55 XP-R nr 55381 + ISOCHECK-SRB nr ISO0571
Certificate	Calibration No	174/87/LA/P/2021 02.04.2021 T146/PMT/2021 12.05.2021 G-103/21-72/21 19.03.2021
Issued by		PLUM Sp. z o.o. KLEOSIN CZAH-POMIAR Sp. z o.o. KATOWICE ZAP J.FIRGANEK BESTWINKA
Date of issue the certificate of calibration		02.04.2021 12.05.2021 19.03.2021
Expiration date of the certificate of calibration		-

Test Report No PW/22/11/22

8. CERTIFICATE OF ACCREDITATION

POLSKIE CENTRUM AKREDYTACJI
POLISH CENTRE FOR ACCREDITATIONSygnatariusz EA MLA
EA MLA SignatoryCERTYFIKAT AKREDYTACJI
LABORATORIUM BADAWCZEGO
ACCREDITATION CERTIFICATE OF TESTING LABORATORY

Nr AB 994

Potwierdza się, że: / This is to confirm that:

„PROFTECH” Sp. z o.o.
ul. Kurta Aldera 44, 41-506 Chorzówspełnia wymagania normy PN-EN ISO/IEC 17025:2018-02
meets requirements of the PN-EN ISO/IEC 17025:2018-02 standardAkredytowana działalność jest określona w Zakresie Akredytacji Nr AB 994
Accredited activity is defined in the Scope of Accreditation No AB 994Akredytacja pozostaje w mocy pod warunkiem przestrzegania
wymagań jednostki akredytującej określonych w kontrakcie Nr AB 994
This accreditation remains in force provided the Laboratory observes
the requirements of Accreditation Body defined in the Contract No AB 994Akredytacji udzielono dnia 30.01.2009 r.
Accreditation was granted on 30.01.2009DYREKTOR
POLSKIEGO CENTRUM AKREDYTACJI

LUCYNA OLBORSKA

Warszawa, dnia 9 grudnia 2019 roku

Test Report No PW/22/11/22

9. DIOXINS AND FURANS ANALYSIS RESULTS



Attachment no. 1 to the Certificate of Analysis for work order PR22A6451

Sample: P/63/10/22

Measurement results PCDD/Fs:

Sample: P/63/10/22		Final extract [µl]: 60			
		Injection volume [µl]: 4			
		Acquisition date [d.m.y h:m]: 27.10.22 15:43			
2,3,7,8-PCDD/Fs	Result [ng/sample]	Limit of Detection [ng/sample]	Limit of Quantification [ng/sample]	⁴ I-TEFs	I-TEQ Upperbound [ng/sample]
2,3,7,8-TCDD	< 0.0023	0.0023	0.0046	1	0.0023
1,2,3,7,8-PeCDD	< 0.0045	0.0045	0.0091	0.5	0.0023
1,2,3,4,7,8-HxCDD	< 0.007	0.007	0.014	0.1	0.0007
1,2,3,6,7,8-HxCDD	< 0.007	0.007	0.014	0.1	0.0007
1,2,3,7,8,9-HxCDD	< 0.007	0.007	0.014	0.1	0.0007
1,2,3,4,6,7,8-HpCDD	< 0.044	0.022	0.044	0.01	0.00044
OCDD	< 0.02	0.02	0.04	0.001	0.00002
2,3,7,8-TCDF	0.016	0.0025	0.0051	0.1	0.0016
1,2,3,7,8-PeCDF	< 0.0044	0.0044	0.0087	0.05	0.00022
2,3,4,7,8-PeCDF	< 0.0087	0.0044	0.0087	0.5	0.0044
1,2,3,4,7,8-HxCDF	0.029	0.0064	0.013	0.1	0.0029
1,2,3,6,7,8-HxCDF	0.031	0.0064	0.013	0.1	0.0031
1,2,3,7,8,9-HxCDF	< 0.0064	0.0064	0.013	0.1	0.00064
2,3,4,6,7,8-HxCDF	0.054	0.0064	0.013	0.1	0.0054
1,2,3,4,6,7,8-HpCDF	0.04	0.0079	0.016	0.01	0.0004
1,2,3,4,7,8,9-HpCDF	< 0.0079	0.0079	0.016	0.01	0.000079
OCDF	< 0.01	0.01	0.021	0.001	0.00001
I-TEQ from quantified 2,3,7,8-PCDD/Fs - "Lowerbound"					0.013
I-TEQ from 2,3,7,8-PCDD/Fs - "Mediumbound"					0.02
Maximum possible I-TEQ - "Upperbound"					0.026
PCDDs	Result [ng/sample]	PCDFs	Result [ng/sample]		
Tetra-CDDs	< 0.051	Tetra-CDFs	0.82		
Penta-CDDs	< 0.064	Penta-CDFs	0.18		
Hexa-CDDs	< 0.07	Hexa-CDFs	0.24		
Hepta-CDDs	< 0.044	Hepta-CDFs	0.075		
OCDD	< 0.02	OCDF	< 0.01		

⁴I-TEF according to NATO.

Limits of quantification are defined as double of the detection limits.

The limit of detection is defined as the amount of analyte producing a signal with S/N ≥ 3.

The value of the detection limit is mentioned as the actual value at the acquisition date.

Measurement uncertainty is expressed as a double (k=2) relative standard deviation (RSD%), and corresponds to 95% confidence interval.

Estimation of uncertainty of each 2,3,7,8-PCDD/F congener is 30% and total I-TEQ is 20%.

These values were ensured by analyses of certified reference material under conditions of internal reproducibility.

Results marked with "<" are below limit of detection or quantification.

"Lowerbound" and "Upperbound" are levels defined in Regulation 2017/644 and EN 1948-4.

"Mediumbound" is levels defined in Regulation 2017/644.

Test Report No PW/22/11/22



Attachment no. 1 to the Certificate of Analysis for work order PR22A6451

Sample:

P/63/10/22

Standards recovery:

Sample: P/63/10/22					
		Final extract [µl]:		60	
		Injection volume [µl]:		4	
		Acquisition date [d.m.y h:m]:		27.10.22 15:43	
Extraction standard	Recovery [%]	Acceptable range [%]		Accept. rec. with respect to	
		Basic	Extended	basic range	extended range
PCDDs					
13C12 - 2,3,7,8-TCDD	73	50 - 130	30 - 150	YES	-
13C12 - 1,2,3,7,8-PeCDD	68	50 - 130	30 - 150	YES	-
13C12 - 1,2,3,4,7,8-HxCDD	57	50 - 130	30 - 150	YES	-
13C12 - 1,2,3,6,7,8-HxCDD	68	50 - 130	30 - 150	YES	-
13C12 - 1,2,3,4,6,7,8-HpCDD	51	40 - 130	20 - 150	YES	-
13C12 - OCDD	62	40 - 130	20 - 150	YES	-
PCDFs					
13C12 - 2,3,7,8-TCDF	56	50 - 130	30 - 150	YES	-
13C12 - 2,3,4,7,8-PeCDF	57	50 - 130	30 - 150	YES	-
13C12 - 1,2,3,4,7,8-HxCDF	51	50 - 130	30 - 150	YES	-
13C12 - 1,2,3,6,7,8-HxCDF	50	50 - 130	30 - 150	YES	-
13C12 - 2,3,4,6,7,8-HxCDF	64	50 - 130	30 - 150	YES	-
13C12 - 1,2,3,4,6,7,8-HpCDF	77	40 - 130	20 - 150	YES	-
13C12 - OCDF	68	40 - 130	20 - 150	YES	-
Sampling standard	Recovery [%]	Acceptable range [%]		Rec. in range?	
13C12-1,2,3,7,8-PeCDF	84	> 50		YES	
13C12-1,2,3,7,8,9-HxCDF	60	> 50		YES	
13C12-1,2,3,4,7,8,9-HpCDF	60	> 50		YES	

Test Report No PW/22/11/22

10. MEASUREMENT PLANE SCHEME

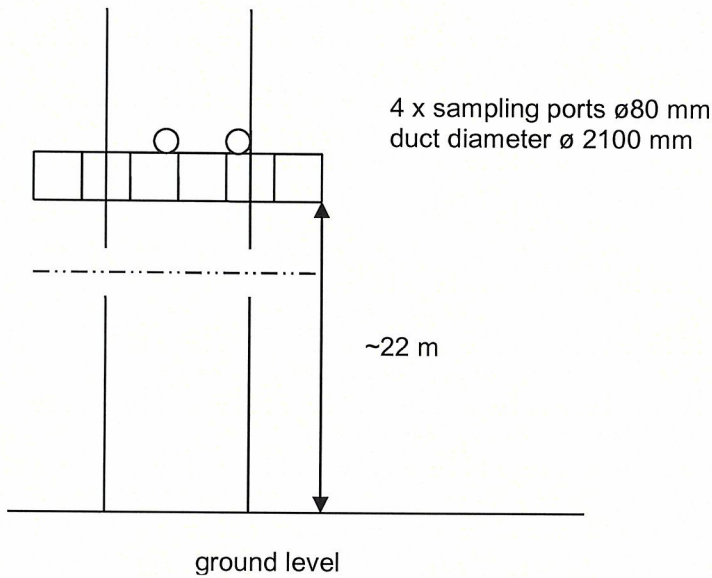

Approved by
DYKUSZ
INSPEKTOR
inż. Dariusz G.
.....
Name and Signature

END OF REPORT