



PROFTECH
SPÓŁKA Z O.O.



AB 994

*Research laboratory
accredited by PCA,
Nr AB 994*

Scopes of accreditation:

- concentration and mass measurements of flow of fine particles
- measurements of concentration and mass flow of SO₂, NO_x, CO
- concentration measurements of CO₂, O₂
- concentration and mass flow measurements of OWO
- sampling for mass concentration determination of PCDD/PDF and dioxin type PCB
- sampling for concentration determination of (As; Cd; Cr; Co; Cu; Mn; Ni; Pb; Sb; Tl; V)
- sampling for concentration determination of Hg
- sampling and determination of concentration and mass flow of HCl
- sampling and determination of concentration and mass flow of HF
- sampling for determining the concentration of individual gaseous organic compounds
- calibration of Automated Monitoring systems,
- QAL2 procedure
- annual performance test of Automated Monitoring Systems, AST procedure
- noise measurement from machinery, installations and industrial plants

Chorzów, July 09th 2024
Our ref. No.: PW/23/07/24

Report No PW/23/07/24

on concentration measurements of dioxins, furans, heavy metals (As; Cd; Cr; Co; Cu; Mn; Ni; Pb; Sb; Tl; V and Hg) emitted into environment from stationary emission source No. 001 (waste incineration boiler stack), located at UAB Vilniaus Kogeneracinė Jėgainė, Jočionių g. 13, 02300 Vilnius

Client name and address:

UAB Vilniaus Kogeneracinė Jėgainė
Žvejų St. 14,
LT-09310 Vilnius

Developed by:

mgr Grzegorz Bortel

Calculation and data transfer checked by:

inż. Dariusz Guja

Verified by:

Company manager - inż. Dariusz Guja

Copy number: 1/3

ul. Kurta Aldera 44
41-506 Chorzów
tel/fax: 0 32 247 37 24

www.proftech.com.pl
e-mail: proftech@proftech.com.pl

NIP: 627 252 46 31
KRS: 0000773369

bank account : PKO BANK POLSKI S.A. O/Katowice : IBAN PL62 1440 1172 0000 0000 0353 4332

Test Report No PW/23/07/24

List of contents:

- 1. PURPOSE AND SCOPE OF THE REPORT**
- 2. BASIS OF MEASUREMENTS EXECUTION**
- 3. MEASUREMENT TEAM**
- 4. MEASUREMENT RESULTS SUMMARY**
- 5. DESCRIPTION OF THE MEASUREMENT METHOD**
- 6. MEASUREMENT RESULTS**
- 7. MEASUREMENT DEVICES**
- 8. CERTIFICATE OF ACCREDITATION**
- 9. DIOXINS AND FURANS ANALYSIS RESULTS**
- 10. MEASUREMENT PLANE SCHEME**

Test Report No PW/23/07/24**4. MEASUREMENT RESULTS SUMMARY**

Below are presented measurement results summary, full measurement results are presented in chapter No 6, at page 9, 12 and 13.

Stationary emission source No. 001 (waste incineration boiler stack)	Concentration of the substance in the gas in the reference conditions O ₂ ref. 11%	PCDDF*	ng/m ³ ref.	0,0026
	Emission limits	PCDDF	ng/m ³ ref.	0,06
	Transgresssion	PCDDF	ng/m ³ ref.	-
	Concentration of the substance in the gas in the reference conditions O ₂ ref. 11%	Cd*+Tl*	mg/m ³ ref.	0,0035
		Hg*	mg/m ³ ref.	0,002016
		Sb*+As*+Cr*+Co*+Mn*+Cu*+Ni*+Pb*+V*	mg/m ³ ref.	0,028
	Emission limits	Cd+Tl	mg/m ³ ref.	0,02
		Hg	mg/m ³ ref.	0,005
		Sb+As+Cr+Co+Mn+Cu+Ni+Pb+V	mg/m ³ ref.	0,3
	Transgresssion	Cd+Tl	mg/m ³ ref.	-
		Hg	mg/m ³ ref.	-
		Sb+As+Cr+Co+Mn+Cu+Ni+Pb+V	mg/m ³ ref.	-

*- the results obtained from the subcontractor (accredited)

Test Report No PW/23/07/24

5. DESCRIPTION OF THE MEASUREMENT METHOD**Measurement of the gas volumetric flow**

The flow rate and density of flue gases were determined according to Polish Standard PN-Z-04030-7:1994 „Testing of particulate content. The gravimetric method measurement of concentration and particulate mass flow in flue gases" Gravimetric dust monitor type MEGASYSTEM X-1 APIS and type "S" Pitot tube were used for the measurements. Measurement is accredited.

Accreditation range: differential pressure: > 10 Pa

Measurement O₂ content

The concentration of O₂ was determined using gas analyzers HORIBA PG-350E-HR and HORIBA PG-350E-EU equipped with testing probes 1750 mm long. The measurements were taken according to the procedure described in measurement unit as well as to EN Standard PN-EN 14789:2017 "Stationary source emissions - Determination of volume concentration of oxygen O₂ - Reference method - Paramagnetism". Measurement is accredited.

Accreditation range: O₂ content: 3-21%

Measurement CO₂ content

The concentration of CO₂ was determined using gas analyzers HORIBA PG-350E-HR and HORIBA PG-350E-EU equipped with testing probes 1750 mm long. The measurements were taken according to the procedure described in measurement unit as well as to ISO Standard ISO 10396:2007 "Stationary Source Emissions - Sampling For The Automated Determination Of Gas Concentrations ". Measurement is accredited.

Accreditation range: CO₂ content: 0,1-20%

Measurement of heavy metals content

Sampling for the determination of concentrations and emissions of heavy metals (Cd, Tl, Sb , As, Cr, Co, Cu , Mn , Ni , Pb, V) was performed according to PN -EN 14385 : 2005. Analysis of metals (Cd , Tl , Sb , As, Cr, Co, Cu , Mn , Ni , Pb, V) was performed in the laboratory of EUROFINS OBIKŚ Sp. z o.o. in Katowice , accredited in this regard by the Polish Centre of Accreditation No. AB 213

Test Report No PW/23/07/24

Measurement of mercury (Hg) content

Sampling for the determination of concentrations and emissions of mercury (Hg) was made according to PN -EN 13211 + AC : 2006. Analysis of mercury (Hg) was made in a laboratory EUROFINS OBIKŚ Sp. z o.o. in Katowice, accredited in this regard by the Polish Centre of Accreditation No. AB 213

PCDD+PCDF sampling and determination

PCDD/DF samples were taken according to the requirements of Polish Standard PN-EN 1948-1:2006 „ Stationary source emissions - Determination of mass concentration of PCDDs/PCDFs and dioxin-type PCBs - Part 1: Sampling of PCDDs/PCDFs”.

The three stages of PCDD/DF concentration and emission determination:

Stage I - sampling

For the determination of mass concentration of PCDD/DF proper sampling plays important role that affects following stages of the testing. The sampling were performed by means of the filtration and condensation method using PCDD/DF sampling conformed to European Standard PN-EN 1948-1:2006.

The following page shows the schematic diagram of the sampling system.

Stage II - laboratory analysis

The samples were analysed at the ALS Czech Republic, s.r.o accredited laboratory following the CSN EN 1948-2,3 methodology: The determination of polychlorinated dibenzo-p-dioxine, dibenzofurans in emission samples with the method of isotop dillution using HRGC/HRMS.

The dioxin and furans analyses were conducted at the ALS Czech Republic, s.r.o. Laboratory, specifically accredited for the test by the Český Institut Pro Akreditaci, o.p.s. , No L1163.

Stage III - development and the results and discussion

The last stage includes results collection from the previous stages, emission calculation and PCDD/DF concentration as well as comparison to the standards in force.

Test Report No PW/23/07/24

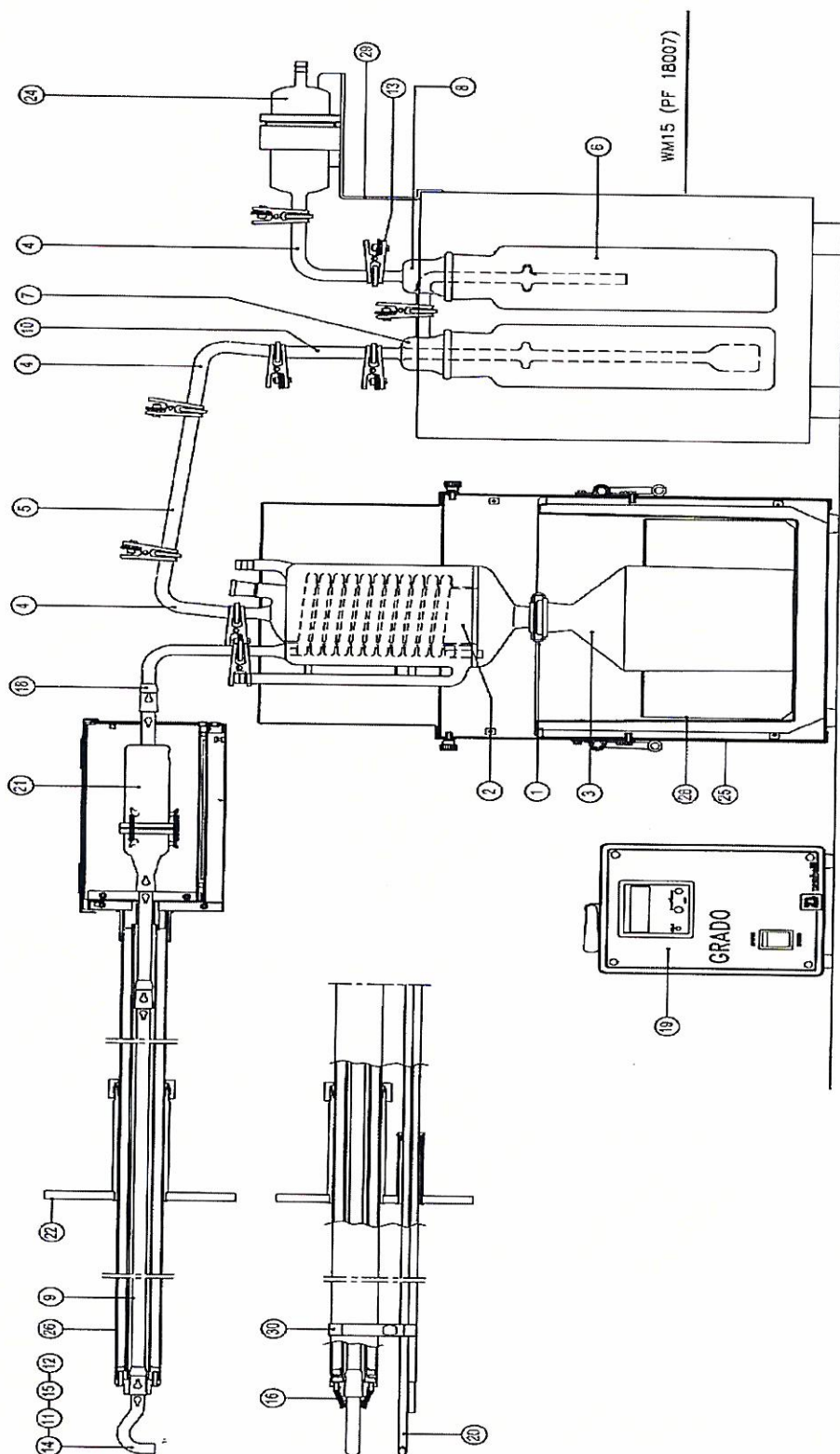

- Opis:
- 1. ferrule
 - 2. cooler
 - 5,10. aspiration path - tubes
 - 13. clamp
 - 20. Pitot tube „S” - type
 - 25. cooler casing
 - 3. condensation pot
 - 6-8. scrubbers
 - 16. holding springs
 - 21. filter casing
 - 26. heated probe
 - 4,18. aspiration path - elbows
 - 9. aspiration path - probe tube
 - 17. aspiration controller
 - 22. yoke
 - 28. cooler coil
 - 11,12,14,15. - aspiration endings
 - 19. temperature controller
 - 24. gas dryer
 - 29.30. support

Test Report No PW/23/07/24

6. MEASUREMENT RESULTS

Test Report No PW/23/07/24

- 1) Plant or unit name¹⁾: **Stationary emission source No. 001 (waste incineration boiler stack)**
 2) Flue gases cleaning unit¹⁾: **Evaporative cooler, hydrated lime and active carbon reactor, bag filters unit (2x4)**
 3) Emission source load during measurements¹⁾: **Boiler load ~23,3 kg/s**
 4) Fuel type or material mass flow in process¹⁾: **Waste ~18,8 t/h**
 5) Location of sampling and measurements: **in duct, after flue gases cleaning unit**

Measurement reference number		05-06-01		X	X					
Date of measurement		05.06.2024								
Measurement time range		09:58-15:59								
Scope of test		Unit	Results	Uncertainty +/-	Method					
Meteorological conditions	Atmospheric pressure		hPa	992,3	X	PN-Z-04030-7:1994				
	Ambient temperature		oC	21						
Measurement plane	Diameter		m	2,10						
	Area		m ²	3,4619						
The parameters of gas in line	Temperature		oC	65			X	PN-EN 14790:2017		
	Static pressure		Pa	-151						
	Differential pressure		Pa	194						
	Gas moistness grade X		kg/kg	0,179						
	Average velocity		m/s	15,5					0,1	PN-Z-04030-7:1994
	Chemical composition	O ₂	%	7,0					0,2	PN-EN 14789:2017
		CO ₂	%	11,6	0,4	ISO 10396:2007				
	Wet gas density during testing		kg/m ³	0,963	X	PN-EN 14790:2017				
	Gas density in normal conditions		kg/m ³ N	1,221		PN-EN 14790:2017				
Gas density in conventional conditions		kg/m ³ U	1,346	PN-EN 14790:2017						
Concentration of the substance in the gas in reference conditions O ₂ ref. 11%	PCDDF*	ng/m ³ ref.	0,0026	0,0008	PN-EN 1948:2006					
Gas volume flow	measurement conditions	m ³ /h	192551	3204	X	PN-Z-04030-7:1994				
	normal conditions	m ³ N/h	151927	2528						
	standard conditions	m ³ U/h	116846	1944						
	reference conditions O ₂ ref. 11%	m ³ ref./h	163585	4044						
Emission limits	PCDDF*	ng/m ³ U	0,06	X	X					
Transgerssion	PCDDF*	ng/m ³ U	-							

*- the results obtained from the subcontractor (accredited)

¹⁾-information obtained from the client

Test Report No PW/23/07/24**Notes:**

Normal conditions designate the temperature of 273 K and pressure of 101,3kPa, defining normal cubic meter m³N. The standard conditions designate the temperature of 273K, pressure of 101,3 kPa and dry gases (steam contents less than 5 g/kg of flue gas), defining standard cubic meter, m³U

The specified expanded uncertainty comes from standard uncertainty multiplied by expansion coefficient k = 2, which provides 95% level of confidence for normal distribution. Uncertainty takes into account the sampling and analysis.

Registry of samples delivered to the laboratory: P/01/06/24, P/02/06/24

Date of delivery to the laboratory: 11.06.2024

Date of analysis: 11.06.2024 - 26.06.2024

Field blanks:

ID/ number of sample	Type of substance	The criterion of the blank [ng/m ³] 11%O ₂	The value of the blank [ng/m ³] 11% O ₂	Result [+/-]
P/02/06/24	PCDD/DF	0,01	0,0019	+

PCDD/DF (PN-EN 1948:2006):

sampling method:	condensation - adsorption method		
filter parameters:	19 x 90 mm, filter efficiency: 99,998 %		
sampling plane:	2 measurement axis		
oxygen reference :	11 %		
time of dioxins and furans measurement:	09:58 – 15:59 (360,1 min)		
nozzle diameter:	6	mm	
probe temperature:	120	°C	
scrubbers temperature	5	°C	
aspired gas volume	6,21	m ³	
average sampling flow	17,3	l/min	
izokinetic ratio:	95,5	%	
leak test:	+ / +		
gas meter temperature	28	°C	
gas meter pressure	0	bar	
spiking pattern:	filter surface		
absorption solution:	100 ml H ₂ O dest. + 50 ml 2-etoksyetanol		
recovery:	56 %	¹³ C ₁₂ -2,3,4,7,8-PECDF,	/>50%/
	60 %	¹³ C ₁₂ -1,2,3,6,7,8-HxCDF,	/>50%/
	60 %	¹³ C ₁₂ -1,2,3,4,6,7,8 HpCDF.	/>50%/
TEQ sample mass:	0,020	ng	

Test Report No PW/23/07/24

- 1) Plant or unit name¹⁾: **Stationary emission source No. 001 (waste incineration boiler stack)**
 2) Flue gases cleaning unit¹⁾: **Evaporative cooler, hydrated lime and active carbon reactor, bag filters unit (2x4)**
 3) Emission source load during measurements¹⁾: **Boiler load ~23,3 kg/s,**
 4) Fuel type or material mass flow in process¹⁾: **Waste ~18,8 t/h**
 5) Location of sampling and measurements: **in duct, after flue gases cleaning unit**

Measurement reference number			05-06-01			X	X	X	
Date of measurement			05.06.2024						
Measurement time range			10:04-10:41	10:49-11:26	11:31-12:07				
Scope of test		Unit	Results			Average	Uncertainty +/-	Method	
Meteorological conditions	Atmospheric pressure	hPa	991,3	991,1	990,8	991,1	0,9	PN-Z-04030-7:1994	
	Air temperature	oC	21	21	21	21			
Measurement plane	Diameter	m	2,10						
	Area	m ²	3,4619						
Stack gas parameters	Temperature	oC	65,1	65,5	65,8	65,5	1,3		
	Static pressure	Pa	-142,1	-145,5	-152,5	-146,7	5,1		
	Dynamic pressure	Pa	144,2	155,6	155,2	151,7	1,3		
	Gas moistness grade X	kg/kg	0,180	0,180	0,180	0,180	0,0046		PN-EN 14790:2017
	Average velocity	m/s	13,9	14,4	14,4	14,2	0,2		PN-Z-04030-7:1994
	Chemical composition	O ₂	%	6,90	7,10	7,00	7,00		0,18
		CO ₂	%	11,60	11,40	11,50	11,50	0,44	ISO 10396:2007
	Wet gas density during testing	kg/m ³	0,963	0,961	0,960	0,961		PN-Z-04030-7:1994	
	Gas density in normal conditions	kg/m ³ N	1,220	1,219	1,220	1,220		PN-Z-04030-7:1994	
Gas density in standard conditions	kg/m ³ U	1,345	1,344	1,345	1,345		PN-Z-04030-7:1994		
Concentration of the substance in the gas in reference conditions O ₂ ref. 11%	As gaseus*	mg/m ³ _{ref}	< 0,001854	< 0,001763	< 0,001757	< 0,001791	0,000465	PN-EN 14385:2005	
	As dust*	mg/m ³ _{ref}	< 0,002343	< 0,002257	< 0,002260	< 0,002286	0,000588	PN-EN 14385:2005	
	As*	mg/m ³ _{ref}	< 0,004196	< 0,004020	< 0,004016	< 0,004077	0,000750	PN-EN 14385:2005	
	Sb gaseus*	mg/m ³ _{ref}	< 0,003707	< 0,003525	< 0,003513	< 0,003582	0,000930	PN-EN 14385:2005	
	Sb dust*	mg/m ³ _{ref}	< 0,004685	< 0,004514	< 0,004519	< 0,004573	0,001176	PN-EN 14385:2005	
	Sb*	mg/m ³ _{ref}	< 0,008393	< 0,008039	< 0,008032	< 0,008155	0,001499	PN-EN 14385:2005	
	Cd gaseus*	mg/m ³ _{ref}	< 0,000741	< 0,000705	< 0,000703	< 0,000716	0,000187	PN-EN 14385:2005	
	Cd dust*	mg/m ³ _{ref}	< 0,000056	< 0,000054	< 0,000054	< 0,000055	0,000229	PN-EN 14385:2005	
	Cd*	mg/m ³ _{ref}	< 0,000798	< 0,000759	< 0,000757	< 0,000771	0,000296	PN-EN 14385:2005	
	Co gaseus*	mg/m ³ _{ref}	< 0,000148	< 0,000141	< 0,000141	< 0,000143	0,000037	PN-EN 14385:2005	
	Co dust*	mg/m ³ _{ref}	< 0,000187	< 0,000181	< 0,000181	< 0,000183	0,000047	PN-EN 14385:2005	
	Co*	mg/m ³ _{ref}	< 0,000336	< 0,000322	< 0,000321	< 0,000326	0,000060	PN-EN 14385:2005	
	Mn gaseus*	mg/m ³ _{ref}	0,001180	0,002482	0,001841	0,001834	0,000481	PN-EN 14385:2005	
	Mn dust*	mg/m ³ _{ref}	0,001376	0,001296	0,001030	0,001234	0,000320	PN-EN 14385:2005	
	Mn*	mg/m ³ _{ref}	0,002556	0,003778	0,002871	0,003069	0,000578	PN-EN 14385:2005	
	Cu gaseus*	mg/m ³ _{ref}	0,011952	0,008827	0,013407	0,011395	0,002979	PN-EN 14385:2005	
	Cu dust*	mg/m ³ _{ref}	0,001801	0,002058	0,003669	0,002510	0,000655	PN-EN 14385:2005	
	Cu*	mg/m ³ _{ref}	0,013753	0,010886	0,017076	0,013905	0,003050	PN-EN 14385:2005	
	Ni gaseus*	mg/m ³ _{ref}	< 0,000297	0,000338	0,000408	0,000348	0,000091	PN-EN 14385:2005	
	Ni dust*	mg/m ³ _{ref}	< 0,000375	< 0,000361	< 0,000362	< 0,000366	0,000095	PN-EN 14385:2005	
	Ni*	mg/m ³ _{ref}	< 0,000671	0,000700	0,000769	0,000713	0,000132	PN-EN 14385:2005	
	Pb gaseus*	mg/m ³ _{ref}	0,001943	0,008743	0,004722	0,005136	0,001347	PN-EN 14385:2005	
	Pb dust*	mg/m ³ _{ref}	0,001331	< 0,001138	< 0,001139	0,001202	0,000312	PN-EN 14385:2005	
	Pb*	mg/m ³ _{ref}	0,003273	0,009880	0,005861	0,006338	0,001383	PN-EN 14385:2005	

Test Report No PW/23/07/24

	V gaseus*	mg/m ³ _{ref}	< 0,000185	< 0,000176	< 0,000176	< 0,000179	0,000047	PN-EN 14385:2005
	V dust*	mg/m ³ _{ref}	< 0,000234	< 0,000226	< 0,000226	< 0,000229	0,000059	PN-EN 14385:2005
	V*	mg/m ³ _{ref}	< 0,000420	< 0,000402	< 0,000402	< 0,000408	0,000075	PN-EN 14385:2005
	Cr gaseus*	mg/m ³ _{ref}	< 0,000445	< 0,000423	< 0,000422	< 0,000430	0,000112	PN-EN 14385:2005
	Cr dust*	mg/m ³ _{ref}	0,002493	0,001656	0,000960	0,001703	0,000441	PN-EN 14385:2005
	Cr*	mg/m ³ _{ref}	0,002937	0,002079	0,001381	0,002133	0,000455	PN-EN 14385:2005
	Tl gaseus*	mg/m ³ _{ref}	< 0,001854	< 0,001763	< 0,001757	< 0,001791	0,000465	PN-EN 14385:2005
	Tl dust*	mg/m ³ _{ref}	< 0,002343	< 0,002257	< 0,002260	< 0,002286	0,000588	PN-EN 14385:2005
	Tl*	mg/m ³ _{ref}	< 0,004196	< 0,004020	< 0,004016	< 0,004077	0,000750	PN-EN 14385:2005
Gas volume flow	measurement conditions	m ³ /h	172610	179465	179340	177138	2947	PN-Z-04030-7:1994
	normal conditions	m ³ _n /h	136187	141402	141129	139573	2322	
	standard conditions	m ³ _u /h	104718	108705	108499	107307	1785	
	reference conditions O2 ref. 11%	m ³ _{ref} /h	147652	151099	151898	150217	3714	
Emission limits	Cd*+Tl*	mg/m ³ _{ref}	0,02					
	Sb*+As*+Cr*+Co*+Mn*+Cu*+Ni*+Pb*+V*	mg/m ³ _{ref}	0,3					
Concentration of the substance in the gas in reference conditions O2 ref. 11%	Cd*+Tl*	mg/m ³ _{ref}	0,0035					
	Sb*+As*+Cr*+Co*+Mn*+Cu*+Ni*+Pb*+V*	mg/m ³ _{ref}	0,028					

*- the results obtained from the subcontractor (accredited)

¹⁾-information obtained from the client

The notation "< or > y" where y=the value of the mesurand corresponding to the lower/upper limit of the measurement range of the method) means - a test result/result below or above the measurement range of the method. The lower/upper limit of the method's measurement range is assumed for the calculation, respectively. The expanded uncertainty shown is the measurement uncertainty for the value of the lower/upper limit of the measurement range of the method. In the case of converted test results/results obtained from a third-party provider of laboratory services, the measurement range limit of that provider's method is assumed for the calculation.

The measurement range limit for: Cr<0,30 ug/sample / As<1,25 ug/sample / Cd<0,50 ug/sample / Co<0,10 ug/sample / Mn<0,25 ug/sample /Cu<0,20 ug/sample / Ni<0,20 ug/sample / Pb<0,63 ug/sample / Tl<1,25 ug/sample / V<0,125 ug/sample / Sb<2,50 ug/sample

Notes:

Normal conditions designate the temperature of 273 K and pressure of 101,3kPa, defining normal cubic meter m³N. The standard conditions designate the temperature of 273K, pressure of 101,3 kPa and dry gases (steam contents less than 5 g/kg of flue gas), defining standard cubic meter, m³U

The specified expanded uncertainty comes from standard uncertainty multiplied by expansion coefficient k = 2, which provides 95% level of confidence for normal distribution. Uncertainty takes into account the sampling and analysis.

Registry of samples delivered to the laboratory: P/03/06/24 - P/12/06/24

Date of delivery to the laboratory: 10.06.2024

Date of analysis: 10.06.2024 - 19.06.2024

Field blanks:

ID/ number of sample	Type of substance	The criterion of the blank [mg/m ³] 11%O ₂	The value of the blank [mg/m ³] 11% O ₂	Result [+/-]
P/09/06/24	Cd+Tl	0,002	p.o.	+
P/09/06/24	Sb+As+Pb+Cr+Co+Cu+Mn+Ni+V	0,03	p.o.	+

p.o. – below the limit of quantification.

Test Report No PW/23/07/24

- 1) Plant or unit name¹⁾: Stationary emission source No. 001 (waste incineration boiler stack)
- 2) Flue gases cleaning unit¹⁾: Evaporative cooler, hydrated lime and active carbon reactor, bag filters unit (2x4)
- 3) Emission source load during measurements¹⁾: **Boiler load ~23,3 kg/s,**
- 4) Fuel type or material mass flow in process¹⁾: **Waste ~18,8 t/h**
- 5) Location of sampling and measurements: **in duct, after flue gases cleaning unit**

Measurement reference number			05-06-01			X	X	X	
Date of measurement			05.06.2024						
Measurement time range			12:15-12:51	12:57-13:33	13:37-14:14				
Scope of test		Unit	Results			Average	Uncertainty +/-	Method	
Meteorological conditions	Atmospheric pressure	hPa	990,8	990,9	990,8	990,8	0,9	PN-Z-04030-7:1994	
	Air temperature	oC	21	21	21	21			
Measurement plane	Diameter	m	2,10						
	Area	m ²	3,4619						
Stack gas parameters	Temperature	oC	65,7	64,7	63,6	64,7	1,3		
	Static pressure	Pa	-156,1	-150,8	-146,3	-151,1	5,2		
	Dynamic pressure	Pa	166,3	148,5	147,2	154,0	1,3		
	Gas moistness grade X	kg/kg	0,180	0,180	0,180	0,180	0,0046		PN-EN 14790:2017
	Average velocity	m/s	14,9	14,1	14,0	14,3	0,2		PN-Z-04030-7:1994
	Chemical composition	O ₂	%	7,00	7,00	7,00	7,00		0,18
		CO ₂	%	11,50	11,60	11,60	11,57	0,44	ISO 10396:2007
	Wet gas density during testing	kg/m ³	0,960	0,964	0,967	0,963		PN-Z-04030-7:1994	
	Gas density in normal conditions	kg/m ³ N	1,220	1,220	1,220	1,220		PN-Z-04030-7:1994	
Gas density in standard conditions	kg/m ³ U	1,345	1,346	1,346	1,345		PN-Z-04030-7:1994		
Concentration of the substance in the gas in reference conditions O ₂ ref. 11%	Hg gaseus*	mg/m ³ _{ref}	0,0004011	< 0,0001896	< 0,0001849	0,0002585	0,0000650	PN-EN 14385:2005	
	Hg dust*	mg/m ³ _{ref}	< 0,0000503	< 0,0000486	< 0,0000488	< 0,0000492	0,0000120	PN-EN 14385:2005	
	Hg*	mg/m ³ _{ref}	0,0004514	< 0,0002382	< 0,0002338	0,0003078	0,0001090	PN-EN 14385:2005	
Gas volume flow	measurement conditions	m ³ /h	185572	175103	173981	178219	2965	PN-Z-04030-7:1994	
	normal conditions	m ³ _n /h	146063	138254	137811	140709	2341		
	standard conditions	m ³ _u /h	112292	106276	105935	108168	1800		
	reference conditions O ₂ ref. 11%	m ³ _{ref} /h	157209	148787	148309	151435	3743		
Emission limits	Hg*	mg/m ³ _{ref}	0,005						
Concentration of the substance in the gas in reference conditions O ₂ ref. 11%	Hg*	mg/m ³ _{ref}	0,002016						

*- the results obtained from the subcontractor (accredited)

¹⁾-information obtained from the client

The notation "< or > y" where y=the value of the mesurand corresponding to the lower/upper limit of the measurement range of the method) means - a test result/result below or above the measurement range of the method. The lower/upper limit of the method's measurement range is assumed for the calculation, respectively. The expanded uncertainty shown is the measurement uncertainty for the value of the lower/upper limit of the measurement range of the method. In the case of converted test results/results obtained from a third-party provider of laboratory services, the measurement range limit of that provider's method is assumed for the calculation.

The measurement range limit for: Hg<0,25 ug/sample

Test Report No PW/23/07/24

Notes:

Normal conditions designate the temperature of 273 K and pressure of 101,3kPa, defining normal cubic meter m³N. The standard conditions designate the temperature of 273K, pressure of 101,3 kPa and dry gases (steam contents less than 5 g/kg of flue gas), defining standard cubic meter, m³U

The specified expanded uncertainty comes from standard uncertainty multiplied by expansion coefficient k = 2, which provides 95% level of confidence for normal distribution. Uncertainty takes into account the sampling and analysis.

Registry of samples delivered to the laboratory: P/13/06/24 - P/22/06/24

Date of delivery to the laboratory: 10.06.2024

Date of analysis: 10.06.2024 - 19.06.2024

Field blanks:

ID/ number of sample	Type of substance	The criterion of the blank [mg/m ³] 11%O ₂	The value of the blank [mg/m ³] 11% O ₂	Result [+/-]
P/19/06/24	Hg	0,0005	p.o.	+

p.o. – below the limit of quantification.

Test Report No PW/23/07/24

Work parameters of measurement system:**Heavy metals (PN-EN 14385:2005)**

Sampling plane: 2 measurement axis
Sampling: isokinetic [x]
nonisokinetic []
Isokinetic ratio: 103,3 % / 103,2 % / 103,3 %
Sampling time: 36,1 min / 36,1 min / 36,1 min
Sampled volume: 0,601 / 0,628 / 0,628 m³
Filter parameters: FT-50: Ø 0,50 mm, efficiency: 99,990 %, quartz (QMA)
Impingers: impingers set No. 1 (absorption efficiency 97,5 %)
Absorption solution: HNO₃/H₂O₂

Hg (PN-EN 13211 + AC:2006)

Sampling plane: 2 measurement axis
Sampling: isokinetic [x]
nonisokinetic []
Isokinetic ratio: 100,8 % / 104,2 % / 103,8 %
Sampling time: 36,1 min / 36,1 min / 36,1 min
Sampled volume: 0,108 m³ / 0,110 / 0,112 m³
Impingers: impingers set No. 2 (absorption efficiency 97,9 %)
Absorption solution: No. I (manganese (VII) potassium / sulfuric acid (VI))

H₂O (PN-EN 14790:2017)

Sampling plane: 2 measurement axis
Sampling equipment: titanium sampling line
heated probe 2,0 m
sampling pump: PT-01
Cartridge No: H₂O content set No 1
Sampling No: 1 - 6
Sampling time: ~36,1 min
Sampling speed: ~3,0 l/min
H₂O maas: 26,0 g
absorption efficiency: 98,7 %

Test Report No PW/23/07/24**7. MEASUREMENT DEVICES**

Name of measuring device		X1- Apis
Type of measuring device		Isokinetic sampler S/N 0185
Certificate	Calibration No	94/54/LA/P/2023 G-73/23-46/23 65/1/T/23
Issued by		ZAP BESTWINKA LABOSERWIS SP. Z O.O. KATOWICE PLUM SP. Z O.O. KLEOSIN
Date of issue the certificate of calibration		27.02.2023 23.02.2023 02.03.2023
Expiration date of the certificate of calibration		-

Name of measuring device		X1- Apis
Type of measuring device		Isokinetic sampler S/N 0142
Certificate	Calibration No	G-355/22-208/22 239/1/T/22 818/302/LA/P/2022
Issued by		ZAP BESTWINKA LABOSERWIS SP. Z O.O. KATOWICE PLUM SP. Z O.O. KLEOSIN
Date of issue the certificate of calibration		29.08.2022 14.09.2022
Expiration date of the certificate of calibration		-

Name of measuring device		HORIBA
Type of measuring device		PG-350E-EU
Certificate	Calibration No	130/1/AW/21
Issued by		Laboserwis Sp. z o.o. Katowice
Date of issue the certificate of calibration		28.05.2021
Expiration date of the certificate of calibration		-

Name of measuring device		Sampler
Type of measuring device		PT-01
Certificate	Calibration No	G-354/22-208/22 1189/436/LA/T/2022 786/281/LA/P/2022
Issued by		ZAP BESTWINKA PLUM SP. Z O.O. KLEOSIN
Date of issue the certificate of calibration		30.08.2022 06.09.2022 09.09.2022
Expiration date of the certificate of calibration		-

Test Report No PW/23/07/24**8. CERTIFICATE OF ACCREDITATION****POLSKIE CENTRUM AKREDYTACJI**
POLISH CENTRE FOR ACCREDITATIONSygnatariusz EA MLA
EA MLA Signatory**CERTYFIKAT AKREDYTACJI**
LABORATORIUM BADAWCZEGO
ACCREDITATION CERTIFICATE OF TESTING LABORATORY
Nr AB 994

Potwierdza się, że: / This is to confirm that:

„PROFTECH” Sp. z o.o.
ul. Kurta Aldera 44, 41-506 Chorzówspełnia wymagania normy PN-EN ISO/IEC 17025:2018-02
meets requirements of the PN-EN ISO/IEC 17025:2018-02 standardAkredytowana działalność jest określona w Zakresie Akredytacji Nr AB 994
Accredited activity is defined in the Scope of Accreditation No AB 994Akredytacja pozostaje w mocy pod warunkiem przestrzegania
wymagań jednostki akredytującej określonych w kontrakcie Nr AB 994
This accreditation remains in force provided the Laboratory observes
the requirements of Accreditation Body defined in the Contract No AB 994Akredytacji udzielono dnia 30.01.2009 r.
Accreditation was granted on 30.01.2009DYREKTOR
POLSKIEGO CENTRUM AKREDYTACJI

LUCYNA OLBORSKA

Warszawa, dnia 9 grudnia 2019 roku

Test Report No PW/23/07/24

9. DIOXINS AND FURANS ANALYSIS RESULTS

Attachment no. 1 to the Certificate of Analysis for work order PR2469524

Sample: P/01/06/24

ALS SAMPLE ID: PR2469524/ 001

Measurement results PCDD/Fs:

Sample: P/01/06/24		Final extract [µl]: 60			
		Injection volume [µl]: 4			
		Acquisition date [d.m.y h:m]: 18.6.24 3:37			
2,3,7,8-PCDD/Fs	Result [ng/sample]	Limit of Detection [ng/sample]	Limit of Quantification [ng/sample]	⁴ I-TEFs	I-TEQ Upperbound [ng/sample]
2,3,7,8-TCDD	< 0.0021	0.0021	0.0043	1	0.0021
1,2,3,7,8-PeCDD	< 0.0041	0.0041	0.0082	0.5	0.002
1,2,3,4,7,8-HxCDD	< 0.0061	0.0061	0.012	0.1	0.00061
1,2,3,6,7,8-HxCDD	< 0.012	0.0061	0.012	0.1	0.0012
1,2,3,7,8,9-HxCDD	< 0.0061	0.0061	0.012	0.1	0.00061
1,2,3,4,6,7,8-HpCDD	< 0.021	0.011	0.021	0.01	0.00021
OCDD	< 0.0035	0.0035	0.0069	0.001	0.0000035
2,3,7,8-TCDF	< 0.0027	0.0027	0.0055	0.1	0.00027
1,2,3,7,8-PeCDF	< 0.0083	0.0083	0.017	0.05	0.00042
2,3,4,7,8-PeCDF	< 0.017	0.0083	0.017	0.5	0.0083
1,2,3,4,7,8-HxCDF	< 0.0068	0.0068	0.014	0.1	0.00068
1,2,3,6,7,8-HxCDF	< 0.014	0.0068	0.014	0.1	0.0014
1,2,3,7,8,9-HxCDF	< 0.0068	0.0068	0.014	0.1	0.00068
2,3,4,6,7,8-HxCDF	< 0.014	0.0068	0.014	0.1	0.0014
1,2,3,4,6,7,8-HpCDF	< 0.022	0.011	0.022	0.01	0.00022
1,2,3,4,7,8,9-HpCDF	< 0.011	0.011	0.022	0.01	0.00011
OCDF	< 0.0039	0.0039	0.0078	0.001	0.0000039
I-TEQ from quantified 2,3,7,8-PCDD/Fs - "Lowerbound"					0
I-TEQ from 2,3,7,8-PCDD/Fs - "Mediumbound"					0.01
Maximum possible I-TEQ - "Upperbound"					0.02
PCDDs	Result [ng/sample]	PCDFs	Result [ng/sample]		
Tetra-CDDs	< 0.067	Tetra-CDFs	< 0.6		
Penta-CDDs	< 0.12	Penta-CDFs	< 0.32		
Hexa-CDDs	< 0.14	Hexa-CDFs	< 0.11		
Hepta-CDDs	< 0.039	Hepta-CDFs	< 0.044		
OCDD	< 0.0035	OCDF	< 0.0039		

⁴I-TEF according to NATO.

Limits of quantification are defined as double of the detection limits.

The limit of detection is defined as the amount of analyte producing a signal with S/N≥3.

The value of the detection limit is mentioned as the actual value at the acquisition date.

Measurement uncertainty is expressed as a double (k=2) relative standard deviation (RSD%), and corresponds to 95% confidence interval.

Estimation of uncertainty of each 2,3,7,8-PCDD/F congener is 30% and total I-TEQ is 20%.

These values were ensured by analyses of certified reference material under conditions of internal reproducibility.

Results marked with "<" are below limit of detection or quantification.

"Lowerbound" and "Upperbound" are levels defined in Regulation 2017/644 and EN 1948-4.

"Mediumbound" is levels defined in Regulation 2017/644.

Test Report No PW/23/07/24**Attachment no. 1 to the Certificate of Analysis for work order PR2469524**

Sample:

P/01/06/24

Standards recovery:

Sample:		P/01/06/24			
		Final extract [µl]:		60	
		Injection volume [µl]:		4	
		Acquisition date [d.m.y h:m]:		18.6.24 3:37	
Extraction standard	Recovery [%]	Acceptable range [%]		Accept. rec. with respect to	
PCDDs		Basic	Extended	basic range	extended range
13C12 - 2,3,7,8-TCDD	86	50 - 130	30 - 150	YES	-
13C12 - 1,2,3,7,8-PeCDD	61	50 - 130	30 - 150	YES	-
13C12 - 1,2,3,4,7,8-HxCDD	87	50 - 130	30 - 150	YES	-
13C12 - 1,2,3,6,7,8-HxCDD	92	50 - 130	30 - 150	YES	-
13C12 - 1,2,3,4,6,7,8-HpCDD	66	40 - 130	20 - 150	YES	-
13C12 - OCDD	89	40 - 130	20 - 150	YES	-
PCDFs					
13C12 - 2,3,7,8-TCDF	70	50 - 130	30 - 150	YES	-
13C12 - 2,3,4,7,8-PeCDF	80	50 - 130	30 - 150	YES	-
13C12 - 1,2,3,4,7,8-HxCDF	88	50 - 130	30 - 150	YES	-
13C12 - 1,2,3,6,7,8-HxCDF	82	50 - 130	30 - 150	YES	-
13C12 - 2,3,4,6,7,8-HxCDF	81	50 - 130	30 - 150	YES	-
13C12 - 1,2,3,4,6,7,8-HpCDF	76	40 - 130	20 - 150	YES	-
13C12 - OCDF	68	40 - 130	20 - 150	YES	-
Sampling standard	Recovery [%]	Acceptable range [%]		Rec. in range?	
13C12-1,2,3,7,8-PeCDF	56	> 50		YES	
13C12-1,2,3,7,8,9-HxCDF	60	> 50		YES	
13C12-1,2,3,4,7,8,9-HpCDF	60	> 50		YES	

Test Report No PW/23/07/24

10. MEASUREMENT PLANE SCHEME

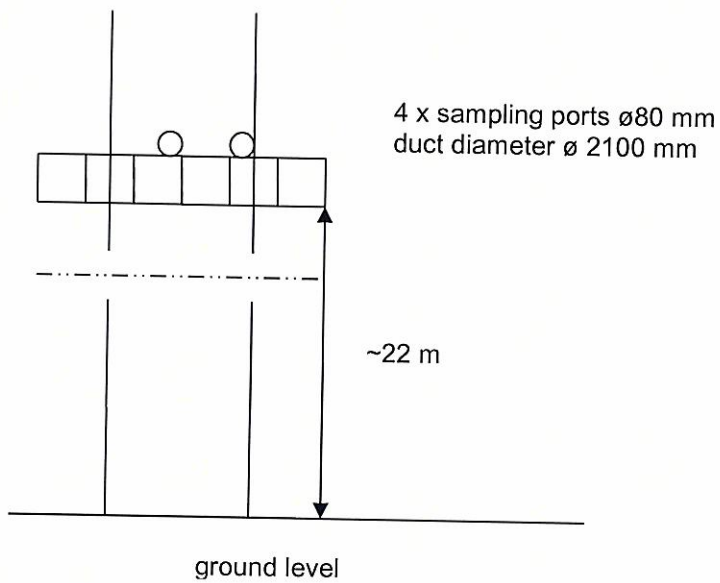

Approved by

.....
Name and Signature

END OF REPORT

