



PROFTECH
SPÓŁKA Z O.O.



AB 994

Research laboratory
accredited by PCA,
Nr AB 994

Scopes of accreditation:

- concentration and mass measurements of flow of fine particles
- measurements of concentration and mass flow of SO₂, NO_x, CO
- concentration measurements of CO₂, O₂
- concentration and mass flow measurements of OWO
- sampling for mass concentration determination of PCDD/PDF and dioxin type PCB
- sampling for concentration determination of (As; Cd; Cr; Co; Cu; Mn; Ni; Pb; Sb; Tl; V)
- sampling for concentration determination of Hg
- sampling and determination of concentration and mass flow of HCl
- sampling and determination of concentration and mass flow of HF
- sampling for determining the concentration of individual gaseous organic compounds
- calibration of Automated Monitoring systems,
- QAL2 procedure
- annual performance test of Automated Monitoring Systems, AST procedure
- noise measurement from machinery, installations and industrial plants

Chorzów, January 15th 2025
Our ref. No.: PW/24/01/25

Report No PW/24/01/25

on concentration measurements of heavy metals (As; Cd; Cr; Co; Cu; Mn; Ni; Pb; Sb; Tl; V) emitted into environment from stationary emission source No. 001 (waste incineration boiler stack), located at UAB Vilniaus Kogeneracinė Jėgainė, Jočionių g. 13, 02300 Vilnius

Client name and address:

UAB Vilniaus Kogeneracinė Jėgainė
Žvejų St. 14,
LT-09310 Vilnius

Developed by:

mgr Grzegorz Bortel

Calculation and data transfer checked by:

inż. Dariusz Guja

Verified by:

Company manager - inż. Dariusz Guja
DYREKTOR

Copy number: 7/8.....

inż. Dariusz Guja

ul. Kurta Aldera 44
41-506 Chorzów
tel/fax: 0 32 247 37 24

www.proftech.com.pl
e-mail: proftech@proftech.com.pl

NIP: 627 252 46 31
KRS: 0000773369

bank account : PKO BANK POLSKI S.A. O/Katowice : IBAN PL62 1440 1172 0000 0000 0353 4332

Test Report No PW/24/01/25

List of contents:

- 1. PURPOSE AND SCOPE OF THE REPORT**
- 2. BASIS OF MEASUREMENTS EXECUTION**
- 3. MEASUREMENT TEAM**
- 4. MEASUREMENT RESULTS SUMMARY**
- 5. DESCRIPTION OF THE MEASUREMENT METHOD**
- 6. MEASUREMENT RESULTS**
- 7. MEASUREMENT DEVICES**
- 8. CERTIFICATE OF ACCREDITATION**
- 9. DIOXINS AND FURANS ANALYSIS RESULTS**
- 10. MEASUREMENT PLANE SCHEME**

Test Report No PW/24/01/25

1. PURPOSE AND SCOPE OF THE REPORT

Purpose of executed measurements was to determine the concentration of heavy metals (As; Cd; Cr; Co; Cu; Mn; Ni; Pb; Sb; Tl; V) emitted to environment from stationary emission source No. 001 (waste incineration boiler stack), located at UAB Vilniaus Kogeneracinė Jėgainė, Jočionių g. 13, 02300 Vilnius

Measurements range:

- Heavy metals (As; Cd; Cr; Co; Cu; Mn; Ni; Pb; Sb; Tl; V) concentration,

The measurements were carried out in accordance with the sampling plan and the described sampling methods.

Operating parameters of the technological installation was obtained from the customer's representative.

2. BASIS OF MEASUREMENTS EXECUTION

The measurements were taken according to the contract No 2023-VKJ-328 dated March 27th 2024.

3. MEASUREMENT TEAM

The measurements taken on December 18th 2024 were executed by the following team:

- Grzegorz Bortel specialist - measurement team leader,
- Karol Sodo specialist,

Test Report No PW/24/01/25**4. MEASUREMENT RESULTS SUMMARY**

Below are presented measurement results summary, full measurement results are presented in chapter No 6, at page 7 and 8

Stationary emission source No. 001 (waste incineration boiler stack)	Concentration of the substance in the gas in the reference conditions O ₂ ref. 11%	Cd*+Tl*	mg/m ³ ref.	0,008
		Sb*+As*+Cr*+Co*+Mn*+Cu*+Ni*+Pb*+V*	mg/m ³ ref.	0,092
	Emission limits	Cd+Tl	mg/m ³ ref.	0,02
		Sb+As+Cr+Co+Mn+Cu+Ni+Pb+V	mg/m ³ ref.	0,3
	Transgresssion	Cd+Tl	mg/m ³ ref.	-
		Hg	mg/m ³ ref.	-
Sb+As+Cr+Co+Mn+Cu+Ni+Pb+V		mg/m ³ ref.	-	

*- the results obtained from the subcontractor (accredited)

Test Report No PW/24/01/25

5. DESCRIPTION OF THE MEASUREMENT METHOD**Measurement of the gas volumetric flow**

The flow rate and density of flue gases were determined according to Polish Standard PN-Z-04030-7:1994 „Testing of particulate content. The gravimetric method measurement of concentration and particulate mass flow in flue gases" Gravimetric dust monitor type MEGASYSTEM X-1 APIS and type "S" Pitot tube were used for the measurements. Measurement is accredited.

Accreditation range: differential pressure: > 10 Pa

Measurement O₂ content

The concentration of O₂ was determined using gas analyzers HORIBA PG-350E-HR and HORIBA PG-350E-EU equipped with testing probes 1750 mm long. The measurements were taken according to the procedure described in measurement unit as well as to EN Standard PN-EN 14789:2017 "Stationary source emissions - Determination of volume concentration of oxygen O₂ - Reference method - Paramagnetism". Measurement is accredited.

Accreditation range: O₂ content: 3-21%

Measurement CO₂ content

The concentration of CO₂ was determined using gas analyzers HORIBA PG-350E-HR and HORIBA PG-350E-EU equipped with testing probes 1750 mm long. The measurements were taken according to the procedure described in measurement unit as well as to ISO Standard ISO 10396:2007 "Stationary Source Emissions - Sampling For The Automated Determination Of Gas Concentrations ". Measurement is accredited.

Accreditation range: CO₂ content: 0,1-20%

Measurement of heavy metals content

Sampling for the determination of concentrations and emissions of heavy metals (Cd, Tl, Sb , As, Cr, Co, Cu , Mn , Ni , Pb, V) was performed according to PN -EN 14385 : 2005. Analysis of metals (Cd , Tl , Sb , As, Cr, Co, Cu , Mn , Ni , Pb, V) was performed in the laboratory of EUROFINS OBIKŚ Sp. z o.o. in Katowice , accredited in this regard by the Polish Centre of Accreditation No. AB 213

Test Report No PW/24/01/25

6. MEASUREMENT RESULTS

Test Report No PW/24/01/25

- 1) Plant or unit name¹⁾: **Stationary emission source No. 001 (waste incineration boiler stack)**
- 2) Flue gases cleaning unit¹⁾: **Evaporative cooler, hydrated lime and active carbon reactor, bag filters unit (2x4)**
- 3) Emission source load during measurements¹⁾: **Boiler load ~70,2 MW**
- 4) Fuel type or material mass flow in process¹⁾: **Waste ~29,2 t/h**
- 5) Location of sampling and measurements: **in duct, after flue gases cleaning unit**

Measurement reference number			18-12-01			X	X	X	
Date of measurement			18.12.2024						
Measurement time range			10:38-11:40	11:46-12:47	12:51-13:52				
Scope of test		Unit	Results			Average	Uncertainty +/-	Method	
Meteorological conditions	Atmospheric pressure	hPa	997,7	997,3	996,7	997,2	0,9	PN-Z-04030-7:1994	
	Air temperature	oC	3	4	4	4			
Measurement plane	Diameter	m	2,10						
	Area	m2	3,4619						
Stack gas parameters	Temperature	oC	32,0	31,6	31,5	31,7	0,6		
	Static pressure	Pa	-77,1	-86,9	-89,6	-84,5	-1,2		
	Dynamic pressure	Pa	120,8	125,5	125,6	124,0	1,4		
	Gas moistness grade X	kg/kg	0,037	0,037	0,037	0,037	0,0009		PN-EN 14790:2017
	Average velocity	m/s	11,7	11,9	11,9	11,8	0,2		PN-Z-04030-7:1994
	Chemical composition	O2	%	6,89	7,34	7,71	7,31		0,40
		CO2	%	11,75	11,62	11,99	11,79	0,45	ISO 10396:2007
	Wet gas density during testing	kg/m3	1,159	1,159	1,162	1,160		PN-Z-04030-7:1994	
	Gas density in normal conditions	kg/m3 N	1,315	1,315	1,318	1,316		PN-Z-04030-7:1994	
Gas density in standard conditions	kg/m3 U	1,346	1,346	1,350	1,347		PN-Z-04030-7:1994		
Concentration of the substance in the gas in reference conditions O2 ref. 11%	As gaseus*	mg/m ³ _{ref}	< 0,005199	< 0,005400	< 0,005068	< 0,005222	0,001358	PN-EN 14385:2005	
	As dust*	mg/m ³ _{ref}	< 0,000459	< 0,000467	< 0,000396	< 0,000441	0,000117	PN-EN 14385:2005	
	As*	mg/m ³ _{ref}	< 0,005658	< 0,005867	< 0,005464	< 0,005663	0,001363	PN-EN 14385:2005	
	Sb gaseus*	mg/m ³ _{ref}	< 0,010398	< 0,010801	< 0,010136	< 0,010445	0,002716	PN-EN 14385:2005	
	Sb dust*	mg/m ³ _{ref}	< 0,000918	< 0,000934	< 0,000793	< 0,000882	0,000234	PN-EN 14385:2005	
	Sb*	mg/m ³ _{ref}	< 0,011316	< 0,011735	< 0,010929	< 0,011327	0,002726	PN-EN 14385:2005	
	Cd gaseus*	mg/m ³ _{ref}	< 0,002080	< 0,002160	< 0,002027	< 0,002089	0,000547	PN-EN 14385:2005	
	Cd dust*	mg/m ³ _{ref}	< 0,000184	< 0,000187	< 0,000159	< 0,000177	0,000047	PN-EN 14385:2005	
	Cd*	mg/m ³ _{ref}	< 0,002264	< 0,002347	< 0,002186	< 0,002266	0,000549	PN-EN 14385:2005	
	Co gaseus*	mg/m ³ _{ref}	< 0,000416	< 0,000432	< 0,000405	< 0,000418	0,000109	PN-EN 14385:2005	
	Co dust*	mg/m ³ _{ref}	< 0,000037	< 0,000037	< 0,000032	< 0,000035	0,000009	PN-EN 14385:2005	
	Co*	mg/m ³ _{ref}	< 0,000453	< 0,000469	< 0,000437	< 0,000453	0,000109	PN-EN 14385:2005	
	Mn gaseus*	mg/m ³ _{ref}	< 0,001040	0,012529	0,177172	0,063580	0,016566	PN-EN 14385:2005	
	Mn dust*	mg/m ³ _{ref}	0,000386	0,000289	0,000222	0,000299	0,000080	PN-EN 14385:2005	
	Mn*	mg/m ³ _{ref}	0,001426	0,012818	0,177394	0,063879	0,016566	PN-EN 14385:2005	
	Cu gaseus*	mg/m ³ _{ref}	< 0,000832	< 0,000864	0,009730	0,003809	0,000998	PN-EN 14385:2005	
	Cu dust*	mg/m ³ _{ref}	0,000544	0,000441	0,000482	0,000489	0,000130	PN-EN 14385:2005	
	Cu*	mg/m ³ _{ref}	0,001376	0,001305	0,010212	0,004298	0,001006	PN-EN 14385:2005	
	Ni gaseus*	mg/m ³ _{ref}	< 0,000832	< 0,000864	< 0,000811	< 0,000836	0,000219	PN-EN 14385:2005	
	Ni dust*	mg/m ³ _{ref}	< 0,000073	< 0,000075	< 0,000063	< 0,000070	0,000019	PN-EN 14385:2005	
	Ni*	mg/m ³ _{ref}	< 0,000905	< 0,000939	< 0,000874	< 0,000906	0,000220	PN-EN 14385:2005	
	Pb gaseus*	mg/m ³ _{ref}	< 0,002620	< 0,002722	< 0,002554	< 0,002632	0,000691	PN-EN 14385:2005	
	Pb dust*	mg/m ³ _{ref}	< 0,000231	< 0,000235	< 0,000200	< 0,000222	0,000059	PN-EN 14385:2005	
Pb*	mg/m ³ _{ref}	< 0,002851	< 0,002957	< 0,002754	< 0,002854	0,000694	PN-EN 14385:2005		

Test Report No PW/24/01/25

	V gaseus*	mg/m ³ _{ref}	< 0,000520	< 0,000540	< 0,000507	< 0,000522	0,000136	PN-EN 14385:2005
	V dust*	mg/m ³ _{ref}	< 0,000046	< 0,000047	< 0,000040	< 0,000044	0,000012	PN-EN 14385:2005
	V*	mg/m ³ _{ref}	< 0,000566	< 0,000587	< 0,000547	< 0,000567	0,000137	PN-EN 14385:2005
	Cr gaseus*	mg/m ³ _{ref}	< 0,001248	< 0,001296	0,002027	0,001524	0,000399	PN-EN 14385:2005
	Cr dust*	mg/m ³ _{ref}	< 0,000110	< 0,000112	< 0,000095	< 0,000106	0,000028	PN-EN 14385:2005
	Cr*	mg/m ³ _{ref}	< 0,001358	< 0,001408	0,002122	0,001629	0,000400	PN-EN 14385:2005
	Tl gaseus*	mg/m ³ _{ref}	< 0,005199	< 0,005400	< 0,005068	< 0,005222	0,001358	PN-EN 14385:2005
	Tl dust*	mg/m ³ _{ref}	< 0,000459	< 0,000467	< 0,000396	< 0,000441	0,000117	PN-EN 14385:2005
	Tl*	mg/m ³ _{ref}	< 0,005658	< 0,005867	< 0,005464	< 0,005663	0,001363	PN-EN 14385:2005
Gas volume flow	measurement conditions	m ³ /h	145815	148557	148432	147602	2728	PN-Z-04030-7:1994
	normal conditions	m ³ _n /h	128442	130979	130819	130080	2404	
	standard conditions	m ³ _s /h	121043	123435	123267	122582	2265	
	reference conditions O2 ref. 11%	m ³ _{ref} /h	170797	168668	163859	167774	7384	
Emission limits	Cd*+Tl*	mg/m ³ _{ref}	0,02					
	Sb*+As*+Cr*+Co*+Mn*+Cu*+Ni*+Pb*+V*	mg/m ³ _{ref}	0,3					
Concentration of the substance in the gas in reference conditions O2 ref. 11%	Cd*+Tl*	mg/m ³ _{ref}	0,008					
	Sb*+As*+Cr*+Co*+Mn*+Cu*+Ni*+Pb*+V*	mg/m ³ _{ref}	0,092					

*- the results obtained from the subcontractor (accredited)
¹⁾-information obtained from the client

The notation "< or > y" where y=the value of the mesurand corresponding to the lower/upper limit of the measurement range of the method) means - a test result/result below or above the measurement range of the method. The lower/upper limit of the method's measurement range is assumed for the calculation, respectively. The expanded uncertainty shown is the measurement uncertainty for the value of the lower/upper limit of the measurement range of the method. In the case of converted test results/results obtained from a third-party provider of laboratory services, the measurement range limit of that provider's method is assumed for the calculation.

The measurement range limit for: Cr<0,30 ug/sample / As<1,25 ug/sample / Cd<0,50 ug/sample / Co<0,10 ug/sample / Mn<0,25 ug/sample / Cu<0,20 ug/sample / Ni<0,20 ug/sample / Pb<0,63 ug/sample / Tl<1,25 ug/sample / V<0,125 ug/sample / Sb<2,50 ug/sample

Notes:

Normal conditions designate the temperature of 273 K and pressure of 101,3kPa, defining normal cubic meter m³N. The standard conditions designate the temperature of 273K, pressure of 101,3 kPa and dry gases (steam contents less than 5 g/kg of flue gas), defining standard cubic meter, m³U

The specified expanded uncertainty comes from standard uncertainty multiplied by expansion coefficient k = 2, which provides 95% level of confidence for normal distribution. Uncertainty takes into account the sampling and analysis.

Registry of samples delivered to the laboratory: P/572/12/24 - P/581/12/24

Date of delivery to the laboratory: 19.12.2024

Date of analysis: 19.12.2024 - 31.12.2024

Field blanks:

ID/ number of sample	Type of substance	The criterion of the blank [mg/m ³] 11%O ₂	The value of the blank [mg/m ³] 11% O ₂	Result [+/-]
P/578/12/24	Cd+Tl	0,002	p.o.	+
P/578/12/24	Sb+As+Pb+Cr+Co+Cu+Mn+Ni+V	0,03	p.o.	+

p.o. – below the limit of quantification.

Test Report No PW/24/01/25

Work parameters of measurement system:**Heavy metals (PN-EN 14385:2005)**

Sampling plane: 2 measurement axis
Sampling: isokinetic [x]
nonisokinetic []
Isokinetic ratio: 107,5 % / 108,7 % / 104,1 %
Sampling time: 61,0 min / 60,1 min / 60,1 min
Sampled volume: 0,143 / 0,140 / 0,155 m³
Filter parameters: FT-50: Ø 0,50 mm, efficiency: 99,990 %, quartz (QMA)
Impingers: impingers set No. 1 (absorption efficiency 98,5 %)
Absorption solution: HNO₃/H₂O₂

H₂O (PN-EN 14790:2017)

Sampling plane: 2 measurement axis
Sampling equipment: titanium sampling line
heated probe 2,0 m
sampling pump: PT-01
Cartridge No: H₂O content set No 1
Sampling No: 1
Sampling time: ~61 min
Sampling speed: ~2,5 l/min
H₂O maas: 5,9 g
absorption efficiency: 98,7 %

Test Report No PW/24/01/25**O₂ paramagnetic (PN-EN 14789:2017):**

Range :	0 – 5 %	[]	
	0 – 10 %	[X]	
	0 – 25 %	[]	
Calibration gas:	O ₂ – 8,001%	[X]	R/07W
	O ₂ – 20,018%	[]	R/12W
	N ₂ – 99,99%	[X]	R/17/
Sampling train:	2 measurement axis		
Sampling time/ average time:	180 min / 1 min		

O ₂ concentration measurement (paramagnetic):		HORIBA PG-350E-EU (130/1/AW/21)			
check operation		unit	result	criterion	result +/-
„0” after adjustment, without sampling train		%	0,05	± 0,1 [%]*	+
„0” after adjustment, with sampling train	before measurement	%	0,1	± 0,2 [%]**	+
	after measurement	%	0,09	± 0,2 [%]**	+
„Span” after adjustment with sampling train /standard 8,001 % R/07/W analyser range 10%/	before measurement	%	7,95	± 0,2 [%]**	+
	after measurement	%	8,01	± 0,2 [%]**	+
	before measurement time T90	%	7,2	> 7,2 [%]	-----
		sec.	25	< 200 sec.	+

*2 x repeatability „0”; **2% measurement range

Test Report No PW/24/01/25**7. MEASUREMENT DEVICES**

Name of measuring device		X1- Apis
Type of measuring device		Isokinetic sampler S/N 0192
Certificate	Calibration No	2054/696/LA/T/2024 09.10.2024 r. G-401/24-254/24 07.10.2024 r. 1074/409/LA/P/2024 08.10.2024 r.
Issued by		ZAP BESTWINKA PLUM SP. Z O.O. KLEOSIN
Date of issue the certificate of calibration		09.10.2024 07.10.2024 08.10.2024
Expiration date of the certificate of calibration		-

Name of measuring device		HORIBA
Type of measuring device		PG-350E-EU
Certificate	Calibration No	1301/AW/21
Issued by		Laboserwis Sp. z o.o. Katowice
Date of issue the certificate of calibration		28.05.2021
Expiration date of the certificate of calibration		-

Name of measuring device		Sampler
Type of measuring device		PT-01
Certificate	Calibration No	G-354/22-208/22 1189/436/LA/T/2022 786/281/LA/P/2022
Issued by		ZAP BESTWINKA PLUM SP. Z O.O. KLEOSIN
Date of issue the certificate of calibration		30.08.2022 06.09.2022 09.09.2022
Expiration date of the certificate of calibration		-

Test Report No PW/24/01/25**8. CERTIFICATE OF ACCREDITATION****POLSKIE CENTRUM AKREDYTACJI**
POLISH CENTRE FOR ACCREDITATIONSygnatariusz EA MLA
EA MLA Signatory**CERTYFIKAT AKREDYTACJI**
LABORATORIUM BADAWCZEGO
ACCREDITATION CERTIFICATE OF TESTING LABORATORY
Nr AB 994

Powierza się, że: / This is to confirm that:

„PROFTECH” Sp. z o.o.
ul. Kurta Aldera 44, 41-506 Chorzówspełnia wymagania normy PN-EN ISO/IEC 17025:2018-02
meets requirements of the PN-EN ISO/IEC 17025:2018-02 standardAkredytowana działalność jest określona w Zakresie Akredytacji Nr AB 994
Accredited activity is defined in the Scope of Accreditation No AB 994Akredytacja pozostaje w mocy pod warunkiem przestrzegania
wymagań jednostki akredytującej określonych w kontrakcie Nr AB 994
This accreditation remains in force provided the Laboratory observes
the requirements of Accreditation Body defined in the Contract No AB 994Akredytacji udzielono dnia 30.01.2009 r.
Accreditation was granted on 30.01.2009DYREKTOR
POLSKIEGO CENTRUM AKREDYTACJI

LUCYNA OLBORSKA

Warszawa, dnia 9 grudnia 2019 roku

Test Report No PW/24/01/25

9. MEASUREMENT PLANE SCHEME

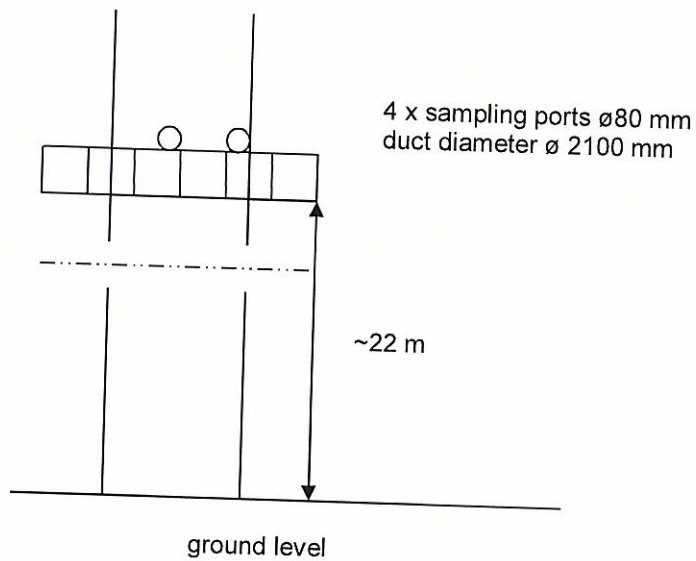

Approved by

DYREKTOR

.....
Name and Signature

inż. Dariusz Guja

END OF REPORT

